



State of Rhode Island  
Department of Administration / Division of Purchases  
One Capitol Hill, Providence, Rhode Island 02908-5855  
Tel: (401) 574-8100 Fax: (401) 574-8387

August 8, 2017

**ADDENDUM #1**

**RFP # 7553502**

**Title: RI WIC Management Information System (MIS) Transfer and Implementation Project**

**Bid Closing Date & Time: September 6, 2017 at 10:00 AM Eastern Time (ET)**

---

**Notice to Vendors**

**ATTACHED ARE VENDOR QUESTIONS WITH STATE RESPONSES. NO FURTHER QUESTIONS WILL BE ANSWERED.**

---

**David J. Francis**  
**Interdepartmental Project Manager**

*Interested parties should monitor this website, on a regular basis, for any additional information that may be posted.*

**Vendor Questions for RFP # 7553502RI WIC Management Information System (MIS) Transfer and Implementation Project**

Question 1 : Whether companies from Outside USA can apply for this?  
(like, from India or Canada)

Answer to question 1: **Because this project involves protected health information (PHI), we are not able to ensure that companies outside of the USA would be able to meet federal requirements and ensure privacy and security under US law.**

Question 2: Whether we need to come over there for meetings?

Answer to question 2: **While some meetings may be attended remotely, there will be some meetings in which the vendor must attend in person.**

Question 3: Can we perform the tasks (related to RFP) outside USA?  
(like, from India or Canada)

Answer to question 3: **Any tasks dealing with protected health information (PHI) cannot be performed outside if the USA. See Question 1.**

Question 4: Can we submit the proposals via email?

Answer to question 4: **No, proposals must be submitted as outlined in the instructions.**

Question 5: Has a budget been identified for this project? May I know an estimated contract value for this project?

Answer to question 5: **Yes, a budget has been identified for this project. No, an estimated contract value cannot be provided for this contract.**

Question 6: Is there an incumbent vendor in contract for this project? If so, may I know the vendor name, contract number and the contract expiry date?

Answer to question 6: **There is no incumbent vendor for this project.**

Question 7: Are you able to provide which vendor was awarded the WIC Management Information System Consultant RFP #7549419?

Answer to question 7: **MAXIMUS**

Question 8: Will this system also support the WIC EBT System? What impact will the MIS system have on the WIC EBT system?

Answer to question 8: **eWIC/EBT is not currently active in RI. The MIS will be configured to support EBT/eWIC.**

Question 9: Has funding for this system been secured? If so, through which source (budget, grants, etc.)?

Answer to question 9: **Funding will be through USDA grants, which have already been approved.**

Question 10: Does the State anticipate any additional solicitations for the WIC MIS project? When do you expect those to be released?

Answer to question 10: **All solicitations for the Transfer and Implementation phase have been released.**

Question 11: In RFP #7553502, page 64 there is a reference to Addendum XII-Liquidated Damages. Also throughout the document, there are multiple references to Addendum I, II, III etc. I can't find those on the procurement site associated with the RFP file. Can you please assist with where I might find these?

Answer to question 11: **Ready for distribution, CONTRACT ADDENDUM.PDF**

Question 12: The RFP states 'It is the desire of RI WIC to kick off both the eWIC implementation project and the MIS transfer and implementation project jointly.' The RFP also states 'In order to issue WIC benefits electronically, the RI WIC Program must implement a new MIS. The RI WIC program will transfer and implement Crossroads, while concurrently implementing eWIC throughout the state.' Is RI WIC open to other MIS solutions besides Crossroads? Is eWIC a new solution being requested through this RFP? If Crossroads has been selected for the MIS solution, is RI WIC open to cloud-based solutions for the eWIC system or has one already been selected? Phase 1, Project Planning / Scope of Work

Answer to question 12: **Crossroads has been selected as our MIS. eWIC is a new solution (the first eWIC system for RI). An eWIC provider with a pre-existing EBT contract with RI has already been selected. Cloud based solutions are possible and will be considered.**

Question 13: What specifically is RI WIC looking to procure from this RFP? Is RI WIC looking for a solution for either the MIS or eWIC systems or has one already been selected? Is RI WIC looking for a system integrator to implement the MIS and/or eWIC systems? Can the solution provider and system integrator be different contractors?

Answer to question 13: **RI is looking for a contractor to, among other things, configure, test, transfer data to, host the Crossroads MIS. RIWIC has already selected an MIS (Crossroads), and an eWIC provider (Xerox). The MIS provider and system integrator can be different contractors.**

Question 14: Would RI WIC consider splitting the RFP into two: one for the MIS solution and services and another for the eWIC solution and services?

Answer to question 14: **RI WIC has an eWIC vendor (Xerox) who will be involved in integrating eWIC into MIS. This RFP will not be subject to splitting.**

Question 15: With a submission deadline of September 6, would RI WIC allow another round of questions? If so, when would they be due?

Answer to question 15: **No, another round of questions will not be allowed.**

Question 16: The Evaluation Criteria appears to grade contractor's personnel, experience, and proposed work plan. Does RI WIC have technical requirements related to the solution? If so, what are these requirements and how are they scored?

Answer to question 16: **As per FNS, mandatory technical minimums have been excluded from this RFP to allow for the maximum number of potential bidders. Technical capacity will be scored in how it effects the evaluation criteria listed in the RFP, in that experience, work plan and personnel information will reflect technical capacity.**

Question 17: Task T.2.6 states 'The TIC will implement a hosting site for the WIC MIS. The site will be operational prior to UAT and remain operational for the duration of the contract. Vendors may propose either a physical hosting site or a cloud-based hosting site. RI WIC requires four (4) environments: Testing, Training, Production and Configuration/Staging.'

Can RI WIC please provide more clarification around this task? Are vendors allowed to propose cloud-based solutions? If so, what part of this RFP can be cloud-based? Design Task T.2.6, page 14 of the RFP

Answer to question 17: **Cloud based solutions may be proposed for a UAT hosting service.**

Question 18: Does RI have any federated authentication or single sign requirements? If so, please elaborate.

Answer to question 18: No

Question 19: Will the new system need to support both paper and EBT or will all participants be migrated to EBT as the new system is rolled out?

Answer to question 19: **All participants will be migrated to EBT as the new system is rolled out. Future developments with Crossroads (and associated eWIC technologies) may affect eWIC/paper checks as they pertain to Farmer's Markets.**

Question 20: To support the lowest cost to the State, while also maintaining quality delivery, will the State allow a combination of onsite and virtual staff for meetings, sessions, training, walkthroughs, Pilot and Rollout.

Answer to question 20: **Some meetings will be allowed in virtual/conference call format, but many will require on-site presence, including (in some phases) multiple consecutive days/weeks on-site.**

Question 21: Please confirm that the 6-month Phase 7 is in addition to the 22-month timeline cited on page 3 and page 8 of the RFP?

Answer to question 21: **The 22-month timeline is the implementation period for the project. The 6-month period in Phase 7 is a warranty period in the event a problem with the transfer and implementation arose that needed to be addressed by the vendor.**

Question 22: On page 3, the contract period is described as one twenty-two (22) month period with no renewals.

Task/Deliverable D.3.1 (on page 17) says the TIC will host the system for three (3) years following implementation, with two 1-year extensions.

Please clarify the total length of the contract period

Answer to question 22: **The length of the contract will be a 22-month Transfer and Implementation process, followed by 3-5 years of hosting. The applicant is asked to submit a budget for the cost of the 22-month transfer and implementation process, pricing for 3 years of hosting, and pricing for 2 additional one year periods of hosting.**

Question 23: The “Important” note states that RI Terms and Conditions and Boiler Plate Contract Language are not subject to editing or negotiation.

However, the majority of state contracts provide a vehicle for discussion of terms and conditions that potential vendors find onerous.

Will the State allow vendors to submit alternate contract language for negotiation, with the understanding that they must accept State’s terms and conditions if the alternate terms are not accepted?

**Answer to question 23: No, for this contract, alternate contract language will not be considered for negotiation.**

Question 24: What information is expected to be exchanged between Crossroads and KIDSNET?

**Answer to question 24: The current WIC MIS supports the following data exchanges with KIDSNET**

**From WIC to KIDSNET: Participant ID number, current WIC status (enrolled/terminated), WIC certification/termination dates, HBG blood test data, HT/WT, risks, demographics.**

**From KIDSNET to WIC: child ID, blood lead test data, immunization information.**

Question 25: Can you provide a list of the expected standard reports?

**Answer to question 25: Existing reports available in the Crossroads system as well as reports indicated by the Functional Requirements Document (FReD) for a Model WIC System (<https://www.fns.usda.gov/apd/wic-fred>)**

Question 26: Please provide additional information and clarity on Data Cleanup.

**Answer to question 26: Assuring that data transferred from the current system (RIWEBS) to Crossroads is imported into the new system in an appropriate manner**

Question 27: Is the TIC only responsible for Unit/Module Testing as defined in the RFP for changes made by the TIC specific for RI or is the TIC expected to provide Unit/Module test results for the entire Crossroads system?

**Answer to question 27 The TIC will be responsible for unit/module testing for the entire Crossroads system in Rhode Island, including both aspects customized for RI WIC and those that are part of the base system.**

**Question 28:** What is the State’s definition of “baseline test”?

What types of tests does the State expect to “ensure that the transferred system operates correctly in the RI WIC environment?”

**Answer to question 28: The definition of a baseline test will be determined later with the cooperation of the TIC and QA contractors, and will be primarily based on test scripts written by the TIC and evaluated/updated by QA.**

**Question 29:** How does the State envision the baseline test working with being part of the Crossroads User Group?

The RFP indicates Rhode Island will join the Crossroads User Group. Source code changes and testing are done through the Crossroads User Group Maintenance and Enhancement Contract. What testing, including regression testing, does the state expect as part of this project that would not be conducted through the prescribed Crossroads User Group processes and procedures?

**Answer to question 29: Code changes and testing are done through the User’s Group procedures, but initial (in RI) configuration and testing will be done without adherence to those procedures.**

**Question 30:** The RFP indicates Rhode Island will take the Crossroads system “as-is.”

Can the State clarify their expectations of system testing since the system is being taken “as is”?

**Answer to question 30: Crossroads source code will be taken as is, meaning no changes will be made to the base system. Crossroads, being a heavily modular system with some inbuilt flexibility, will be configured by the TIC to meet the needs of RI WIC.**

**Question 31:** Is the State requiring the eWIC contractor to provide a trainer to participate/teach/lead in the training classes with the TIC?

**Answer to question 31: The eWIC contractor will provide some guidance and supplemental material to assist the training process, but will likely not have on-site staff to participate/teach/lead these classes.**

**Question 32:** Please confirm testing is to be conducted on converted data only or could be a combination of converted data and TIC provided data?

Answer to question 32: **Converted data only.**

Question 33: Please describe the timeframes desired for testing clock change scenarios. For example, advance one month, six months, one year?

Answer to question 33: **Clock change scenarios should be for periods of time representing typical appointment intervals up to one year.**

Question 34: The RFP indicates Rhode Island will join the Crossroads User Group. Documentation updates are done through the Crossroads User Group Maintenance and Enhancement Contract. Can the State clarify documentation updates as related to this RFP that would not flow through the Crossroads User Group Maintenance and Enhancement Contract?

Answer to question 34: **Document updates will be handled by the TIC through the Transfer and Implementation process. These may include Crossroads UG documents, but due to the customization and configuration that will be specific to RI, the User's Group documents alone will not suffice. Documents reflecting the unique set of configuration decisions and data linkages will be necessary, as well as documentation of testing.**

Question 35: Please provide an example of a "pre-condition" that will need to be supported?

Answer to question 35: **This is determined by the newest version of Crossroads has been tested and approved by the User's Group at the start of the RI MIS configuration stage. Release information for this version will include known bugs and workarounds.**

Question 36: Can the State clarify and expand on the requirement "perform tests to ensure the system is fully operation in each clinic"?

What tests are expected by the State?

Answer to question 36: **Complete workflow from creating a new client record, certification, scheduling, entering measurement data, prescribing food packages, creating an MIS/eWIC card, loading benefits onto the card, and all other local agency functions.**

Question 37: Please define the requirement for "successfully access interfaced systems".



**Answer to question 37: Successfully exchanging necessary data with programs like KIDSNET.**

**Question 38:** Task/Deliverable Requirement T.5.8 says (in reference to the Pilot Phase), “The Vendor will provide weekly pricing in their proposal.”

However, the price sheets—Appendix A and Appendix B—do not provide a format for weekly pricing of this phase. Please clarify how vendors should comply with this weekly pricing requirement.

**Answer to question 38: RI does not have a standard weekly pricing sheet. Weekly pricing information should include staff quantity, staff roles, and cost per week.**

**Question 39:** Can the State expand and clarify “supporting the testing and eventual implementation of each release”?

What is the definition or expectation of supporting testing?

What are the discreet requirements for supporting testing?

**Answer to question 39: Refer to Phase 4 of the RFP**

**Question 40:** Please provide a listing of all hardware and peripherals that must be supported by Crossroads.

**Answer to question 40:**

**Local Agency Hardware (Dell)**

<i>Base Unit</i>	<i>OptiPlex 760 Small Form Factor Base Standard PSU (224-2219)</i>
<i>Processor:</i>	<i>OptiPlex 760, core 2 Duo E7300/2.66GHz,3M, 1066Fsb (311-9514)</i>
<i>Memory:</i>	<i>2GB, Non- ECC,800 MHz DDR2,2 X1 GB OptiPlex (311-7374)</i>
<i>Video Card:</i>	<i>Integrated Video, GMA 4500, Dell OptiPlex 760 and 960 (320-7407)</i>
<i>Hard Drive:</i>	<i>80 GB SATA 3.0 Bb/s and 8 MB DataBurst Cache, Dell OpyiPlex (341-8006)</i>

**State Office Hardware**

<i>Base Unit</i>	<i>OptiPlex 760 Minitower Base Standard PSU (224-2211)</i>
<i>Processor:</i>	<i>OptiPlex 760, core 2 Duo E8400/3.0 GHz, 6M, 1333 FSB (311-9513)</i>
<i>Memory:</i>	<i>3GB, Non- ECC,800 MHz DDR2,3 X1 GB OptiPlex (311-9528)</i>
<i>Video Card:</i>	<i>256MB ATI Radeon HD 3450 Graphics dual DVI and VGA and TV out</i>
<i>Hard Drive:</i>	<i>160 GB SATA 3.0 Bb/s and 8 MB DataBurst Cache, Dell OpyiPlex (341-8006)</i>

Signature Pads (for eWIC)

- Topaz Model T-L BK766SE-BHSB-R
- Topaz Model T-L BK43LC-HSB-R
- Topaz Model T-L460-HSB-R
- Topaz Model T-L461-HSB-R

Question 41: Can the State confirm that it is a TIC requirement to create UAT test scripts?

Are UAT test scripts meant to be created by the QA contractor?

**Answer to question 41: UAT Test scripts are to be made by the TIC and evaluated by the QA contractor, who might then recommend adding/augmenting the scripts.**

Question 42: Can an exception for Pilot Training be added to D.4.5?

Per earlier information in the RFP it appeared that RI trainers would be conducting Pilot training, not the TIC.

**Answer to question 42: No. Pilot training will likely be the most important of the trainings to be evaluated, as it will show changes needed to the process ahead of later, larger trainings.**

Question 43: Is FNS approval required?

If so, have you considered this approval within the 22-month timeline.

**Answer to question 43: FNS approval at certain stages is required and has been incorporated into the current estimated timeline.**

Question 44: The cost of self-learning modules can vary greatly. Will the State specify what is required in the self-learning modules?

**Answer to question 44: Should include a step-by-step guide for each procedure run by the local agency staff, including brief quizzes at the end (quizzes will be scored but scores will not be recorded or stored). Modules should be without video, audio, animation: basic, no-frills stuff with only screenshots and text.**

Question 45: Task/Deliverable Number T.8.3 requires three references for the Project Manager. In the service center approach through which WIC services are provided, key or core staff may not have constant or ongoing contact with clients, and three references may not be feasible for even the most experience personnel.

Will RI change the requirement to two or one references?

Answer to question 45: **No, three references are required.**

Question 46: Government proposals typically require a Transmittal Letter to formally transmit the offer to the customer.

However, the proposal format instructions on page 51 do not identify the need for a Transmittal Letter.

Please confirm that this proposal does not require a signed Transmittal Letter.

Answer to question 46: **A RIVIP registration form is required and can be completed at <https://www.purchasing.ri.gov/RIVIP/VendorRegistration.aspx>. A signed transmittal letter is not required, but is optional.**

Question 47: The Section 5 instructions for the Cost Proposal require a “separate, signed and sealed Cost Proposal.”

We did not see a signature line on the cost worksheets (Appendix A and Appendix B). Please clarify the method for signing the Cost Proposal. Will a signed letter (similar to a Transmittal Letter) meet this requirement?

Answer to question 47: **Yes, a signed transmittal letter will meet this requirement.**

Question 48: The Section 7 "Proposal Submission" instructions state, ". . .should be mailed or hand-delivered in a sealed envelope . . ."

Will the Commonwealth amend this language to read, "should be mailed or hand-delivered in a sealed envelope or other type of sealed container. . ."?

Answer to question 48: **Any sealed container will be accepted, but the technical proposal and the cost proposal must be submitted in two (2) separate sealed envelopes.**

Question 49: Section 7 states that bidders must submit “an original plus four (4) copies.”

Please confirm that the State is expecting an original and four copies for **both** the Technical and Cost proposals.

Answer to question 49: **Confirmed**

Question 50: In the “Anticipated expenses for travel to Rhode Island” section of Appendix A, the RFP list items UAT Training/UAT (40 days), Train the Trainer (3 days), Pilot (40 days), and Rollout (5 days) that do not appear in Appendix B – Cost Worksheet, section Travel Expense to RI.

Does the State anticipate that these items will also be included in Appendix B – Cost Worksheet?

Answer to question 50: **Appendix B amended.**

Question 51: The instructions for responding to the Work Plan/Approach section are open-ended, and allow much discretion to the vendors on the structure of this response.

To ensure that vendors are responding to the specific topics that will be scored in this section (which is worth 30 points in the evaluation), will the State provide a more specific set of topics that need to be addressed in Section 2 Work Plan/Approach?

Answer to question 51: **No, the State cannot provide a more specific set of topics that need to be addressed in Section 2.**

Question 52: Section 1 states "The initial contract period will begin approximately January 1, 2018 for one twenty-two month (22) period. This is a one-time project and will not be renewed upon completion."

Deliverable D.3.1 states "The TIC will be required to host the Crossroads system on behalf of RI for three (3) years after implementation. System hosting throughout statewide implementation will be required of the TIC, with two (2) additional extensions of one year each to be exercised at the discretion of RI WIC see Task T.7.4."

Task T.7.4 states "The TIC will provide pricing for three (3) years of hosting and two (2) additional one (1) year hosting extensions to RI WIC after statewide implementation."

The project is described as 22-month duration yet there is a required Hosting period of 3 to 5 years.

Q: Please clarify whether there will be one contract covering both implementation and hosting (e.g.; more than 22-months) or separate contracts will be executed for transfer/implementation versus hosting.

Answer to question 52: **TIC proposals should include both the transfer and implementation estimates and estimates for 3 years of hosting followed to 2 one year hosting estimates. The hosting phase will begin after the 22-month**

**Transfer and Implementation phase, both will be included on the same contract.**

Question 53: Instruction 14 states that the State has a 10% minority participation goal.

Q: Is there a mandatory 10% minority participation requirement for this project?

Answer to question 53: **Not mandatory, but it is a goal.**

Question 54: There are several references to hosting both prior to UAT and after in Tasks T.2.6., Task T.4.19., Task T.6.7., Task T.7.3., Task T.7.4., Deliverable D.1.4., Deliverable D.3.1., Deliverable D.3.2.

Q1: When is the TIC required to provide hosting during the 22-month implementation schedule?

Q2: When does the required three (3) year hosting service begin?

Q3: What is the TIC responsibility for procuring or providing hosted server and storage capacity? (or will the State provide the hardware to the TIC?)

Q4: Are there any requirements for warranty support of any TIC-provided hardware?

Q5: What geographic requirements exist for location of the primary hosting datacenter and disaster recovery/backup site?

Answer to question 54:

**(Q1) The TIC will be required to provide a testing environment during the T&I phase.**

**(Q2) After the (estimated) 22 month Implementation, the three year hosting period begins.**

**(Q3) The state will provide hardware for this purpose if necessary**

**(Q4) TIC is responsible for patches and updates.**

**(Q5) Main hosting facility and backup facility should be separated by at least 25 miles and draw power from different power grids.**

Question 55: According to WICTechnologyPartners, MIS Source Code is provided by procurement only per the instructions for the individual solicitations.

Q: What are the instructions for obtaining Crossroads Source Code?

Answer to question 55: **Detailed specifications for the Crossroads system can be found by creating an account at <http://www.wictechnologypartners.com/>. Accounts require no special permissions or validations. Once logged in, click the**

**“Resources” link on the home page, then “MIS Documentation”, then “Access Crossroads Support Documentation”.**

Question 56: There appear to be some errors or inconsistencies in the project schedule. For example, there is a 6-month gap between end of Contracts Executed (approx. June 2018) and the start of Design/Development Activities, Design/Development is shown to start two (2) months before Pilot and runs for ten (10) months which would be the month before Closeout, Testing starts two (2) months before Design/Development starts.

Q1: Please confirm the stated timeline is an accurate representation of how the State envisions this project executing.

Q2: Please restate/revise the timeline Milestones/Project Phases in the table to directly reference each of the 11 project phases described in the remainder of Section 3?

Answer to question 56:

**(Q1) Confirmed. The Anticipated Start Dates are accurate, the Timeframes listed are relics from a previous version of the RFP.**

**(Q2) Items marked “Phase 8” through “Phase 11” are pertinent throughout the timeline, and do not belong in any one spot in the milestone schedule.**

Question 57: The Project Timeline does not address any tasks/deliverables beyond "Closeout".

Q: What is the project timeline for the full scope of Phase 7?

Answer to question 57: **3 years with the option to renew for 2 additional one year periods.**

Question 58: Task T.1.3 states “the TIC should plan for ten (10) business days for initial RI WIC review and an additional five (5) business days for reviews of modifications to deliverables”. There approximately 40 key deliverables that are considered critical path deliverables, that account for 400 business days of review and approval.

Q1: Will the State require ALL deliverables to be approved prior to successor activities starting?

Q2: Please list the specific deliverables when must be approved by the State before successor activities can start.

Q3: Please confirm that the stated review/revision timeframe applies to all deliverables identified in the RFP. If not, please identify the deliverables where this planning constraint must be applied

Answer to question 58:

**(Q1) Changed deliverables will require approval, as well as approval of the project plan as a whole, which includes each schedule-estimated deliverable.**

**(Q2) Multiple documents (for example, Plans) are expected to be submitted at the same time, and will be reviewed concurrently, so that the submission of one plan does not mean the next cannot be submitted for 10 days. The following deliverables will NOT need to be approved before successor activities can begin. D9.1, D1.1, D1.5, D1.3, D4.5, D4.6, D4.3, D5.1, D5.2**

**(Q3) . Review/revision applies to all deliverables identified.**

Question 59: Data conversion will be impacted by the old and new system environments.

Q1: Please provide a description of the technical environment (ex; language, database, hosting, architecture) for the existing RIWEBS system.

Q2: Could a data dictionary and data models of RIWEBS be made available so that we can better determine the size of effort for data conversion?

Q3: Please confirm that RIWEBS is the only data source that will be required for conversion.

Answer to question 59:

**(Q1) See Below**

***Platform***

**The application runs on a Citrix presentation server, which will access a database stored on a database server. The Citrix presentation server will be a Microsoft Windows 2008 Server.**

***Application***

**Application - The application is written in Microsoft Visual Basic 6.0 for 32-bit Windows environments. Database**

**The application uses an Oracle server database for storage of data. This database runs on Windows 2008 Server running on a machine configured to be the server.**

S. No.	Server	Configuration	Software
1	End of Day Server	Single Xeon Dual Core, 4 GB RAM, 2 X 146 GB HDD (Mirror)	Windows 2008 Standard Edition
2	Citrix Server 1	Single Xeon Dual Core, 8 GB RAM, 2 X 146 GB HDD (Mirror)	Windows 2008
3	Citrix Server 2	Single Xeon Dual Core, 8 GB RAM, 2 X 146 GB HDD (Mirror)	Windows 2008
4	Database Server	Dual Dual Core, 8 GB RAM, 3 X 300 GB HDD (RAID 5)	Windows 2008
5	ESX Server (will host Secure Gateway, Epad and UAT server, QA server)	Dual Dual Core, 16 GB RAM, 3 X 300 GB HDD (RAID 5)	ESX 3.5 Standard Edition

**(Q2) Ready for distribution, see RIWEBS TABLES LIST.PDF**

**(Q3) Confirmed**

Question 60: There are several references to interfacing with KIDSNET yet there is no description of this system or the interface requirements.

There is also the comment "In the event that development and implementation support of the KIDSNET interface can proceed under this contract, RI WIC will also pursue these activities at their discretion."

Q1: For KIDSNET, please provide system descriptions and narratives/requirements for the desired interfaces so we can understand and estimate the magnitude and complexity of this project requirement.

Q2: What will determine if and when the TIC will be able to proceed with development and implementation of the KIDSNET interface?

Answer to question 60:

**(Q1) Documents ready for distribution. KIDSNET TECHNICAL DESCRIPTION.PDF and WIC SPECS 2011.PDF.**

**(Q2) If during the Design and Development phase, the KIDSNET link seems reasonably feasible, the link will be implemented into the system.**

Question 61: In Phase 2, the RFP states "Because Rhode Island is joining the Crossroads User Group, they are restricted from making any changes to the Crossroads code without following the Crossroads change control process; this process currently prohibits any changes to the source code beyond changes commissioned from the M&E Contractor under the User Group M&E contract."

In Phase 3, the RFP states "RI WIC will be joining the Crossroads User Group and taking the Crossroads system "as-is" meaning there will be no changes to the system code; ..."

Q: Please clarify the TIC responsibility for coordinating any activities with the Crossroads M&E contractor for development and implementation of any required changes to the Crossroads software.

Answer to question 61: **The TIC will not be responsible for the development of any changes to the Crossroads code. The TIC will use existing options within Crossroads to configure the system to the needs of RI WIC. After implementation, when the TIC has shifted from Implementation to hosting, the TIC will be responsible for installing newer, updated versions of Crossroads once they have been developed and tested by the crossroads User's Group.**

Question 62: The RFP states "Because Rhode Island is joining the Crossroads User Group, they are restricted from making any changes to the Crossroads code without following the Crossroads change control process; this process currently prohibits any changes to the source code beyond



changes commissioned from the M&E Contractor under the User Group M&E contract." and "RI WIC will require the design activities for the KIDSNET interface as well as all efforts to design, develop, and support the Xerox interface." These statements seem to contradict each other.

In Phase 3, the RFP states "RI WIC will be joining the Crossroads User Group and taking the Crossroads system "as-is" meaning there will be no changes to the system code; ..."

Q1: Please confirm that the Crossroads system software version that will be available for transfer to Rhode Island fully supports the Xerox EBT interface.

Q2: Please confirm that the TIC will not be responsible for any modifications to Crossroads to support the Xerox EBT interface.

Q3: Please confirm that only the Crossroads M&E Contractor will be allowed to make code changes for Rhode Island's implementation.

Q4: Please list the code changes and anticipated release dates that the Crossroads M&E Contractor will make for Rhode Island's implementation of the Crossroads system.

Answer to question 62:

**(Q1) Confirmed. Crossroads is already interacting with the Xerox EBT interface in other states.**

**(Q2) Modification of the core code of the Crossroads system will be not be necessary or possible for this, however some configuration of this interface will be necessary.**

**(Q3) There will be no source code changes during Implementation.**

**(Q4) None known at this time.**

Question 63: The Description of T.2.4 contains the following text: "RI WIC requires the ability to run three (3) years' worth of standard reports for information independent of the issuance and reconciliation of food instruments (FI)."

Q: Please confirm that "independent of the issuance and reconciliation of food instruments" means that RI is not expecting the conversion of FI data from the legacy system into the new system.

Q: Please clarify if this requirement means that after conversion RI will simply be retaining its existing system in a read-only mode for reporting.

Answer to question 63:

**(Q1) Not confirmed, RI is expecting the FI data to be converted from the legacy system into the new system.**

**(Q2) RI is expecting legacy data to be converted into the new system.**

Question 64: The description of T.2.4 contains the following text: "In addition, RI WIC intends to convert all vendor data".

Q: Please elaborate on specifically the vendor data, including any historical data, that is to be converted.

Answer to question 64: **The Event Log history and Redemption Log history**

Question 65: Tasks T.2.3 and T.3.2 reference an Attachment 2.

Q: Can Attachment 2 be provided?

Answer to question 65: **Ready for distribution (see WIC SPESC 2011.PDF and KIDSNET TECHNICAL DESCRIPTION.PDF)**

Question 66: RI WIC will require the design activities for the KIDSNET interface as well as all efforts to design, develop, and support the Xerox interface.

Development task T.3.2 for development of a KIDSNET interface is labeled as optional.

Q1: Please confirm that should the State require the TIC to develop and implement the KIDSNET interface this will be authorized by a change order (and will not be bid as a separate RFP at a later date).

Q2: For the Proposal, please confirm that the vendor should exclude a pricing estimate for the KIDSNET interface design, development?

Q3: Please describe the conditions under which the KIDSNET interface modification to Crossroads will NOT be developed by the Crossroads M&E Contractor.

Answer to question 66:

**(Q1) Confirmed**

**(Q2) Confirmed**

**(Q3) If during the Design and Development phase, the KIDSNET link seems reasonably feasible, the link will be implemented into the system.**

Question 67: Task T.3.3., Data Conversion, requires that three (3) years of data, as well as all vendor data, be converted from RIWEBS to Crossroads.

Q: Please provide both record counts and approximate sizing for participant, family, certification, issuances, redemptions, education, vendor, and transaction data

Answer to question 67:

**Participant = 34,000**  
**Family (household) = 20,000**  
**Certification = 50,000**  
**Issuances = 1,059,079**  
**Redemptions / transaction data = 821,056**  
**Vendor = 230 (active), 1851 (active and terminated)**

Question 68: Task T.3.4 references an Attachment 4.

Q: Can Attachment 4 be provided?

Answer to question 68: **For Security Policies see <http://operations.doit.ri.gov/policy/>**

Question 69: Q: What roles and responsibilities will the QA Contractor have during UAT?

Answer to question 69: **Supporting the UAT process, including the creation of a UAT data conversion report, a UAT systems installation report, a UAT plan, UAT testing scripts evaluation, and a review and evaluation of T&I and eWIC transfer, modification and technical testing reports and pilot readiness certification, working in coordination and cooperation with TIC, eWIC and State Agency.**

Question 70: Per prior statements in the RFP, the TIC is not allowed to change the Crossroads source code. Unit/Module Testing (Task T.4.3) is usually an activity of the M&E Contractor.

Q: If the awarded contractor is not the Crossroads M&E Contractor, is this task required by the T&I contractor?

Answer to question 70: **Yes. Changes in configuration may help to mitigate or avoid problems found in testing without changing core code, and would at least make RI WIC aware of what problems exist in the system.**

Question 71: The RFP indicates that the only training provided by the TIC is for eWIC, UAT, Train-the-Trainer (for state trainers), and State staff. The RFP also indicates that the only TIC involvement in the Rollout Training is to act as support for the state trainers.

Q1: Please confirm that the TIC is fully responsible for all user training during UAT

Q2: Please confirm that the TIC is fully responsible for all user training of the Pilot clinic staff

Q3: Please confirm that the State's trainers will be responsible for conducting all user training during statewide Rollout.

Q4: Please describe the services and activities expected of the TIC required to "provide support to state trainers".

Answer to question 71  
**(Q1) Confirmed**

**(Q2) Confirmed, they are trained with the State Agency staff during UAT.**

**(Q3) Confirmed**

**(Q4) Answering questions during training when necessary, adding supplemental information to answers provided by state staff and assisting trainees in the use of the hands-on system during training,**

Question 72: Task T.4.4 requires the TIC to submit documentation of any Crossroads defects discovered during testing.

Q: Is there an SLA or defined resolution timeframe within which the Crossroads M&E Contractor will provide a working correction to reported defects?

Answer to question 72: **The M&E contractor will not provide any corrections to defects during the Transfer and Implementation phase. Defects will need to be reported to the State Agency within 48 hours of detection. The State Agency technical staff will determine who holds responsibility for a given defect, as they could occur because of the source code or because of hosting, configuration errors etc.**

Question 73: Q: For Task T.4.6 planning purposes, when would a new release be available from the Crossroads M&E Contractor that contains the new KIDSNET interface?

Answer to question 73: **Due to the RI-only nature of KIDSNET, it is unlikely the Crossroads M&E contractor will release a version of the software that specifically addresses the KIDSNET interface needs. It is more likely that the KIDSNET interface will be completed using some pre-existing framework for interfacing Crossroads with other systems.**

Question 74: Regression Testing is usually an activity of the M&E Contractor.

Q: Please provide a list of regression tests and scripts that will be provided by the Crossroads User Group or the Crossroads M&E Contractor.

Answer to question 74: **The TIC is responsible for test scripts, which will be evaluated by QA.**

Question 75: Task T.4.9 states the TIC will participate in eWIC training.

Q: Where will the eWIC Training be held and what is the duration?

Answer to question 75: **The eWIC training will be held in Providence, RI. Duration has not yet been determined.**

Question 76: Q: For Task T.4.11, where will the Training Materials Walk Through be held?

Answer to question 76: **Training materials walkthrough will occur in Providence, Rhode Island.**

Question 77: Q: Please provide a list of training materials that are being provided by the Crossroads User Group.

Answer to question 77: **The TIC is responsible for training materials, which will be evaluated by QA.**

Question 78: Tasks T.4.15 and T.5.2 requires the TIC to inform the State of equipment that must be procured for UAT, Pilot, and Statewide rollout.

Q: Will the State be procuring all requested/required equipment from an existing master contract or will a new procurement/RFP be required? **The State Master Price Agreements may contain some equipment that will be needed for the project and the state will solicit bids in accordance with purchasing procedures for any items not covered by these agreements. Master Price Agreements can be awarded at any time by the State of RI Division of Purchases.**

Q1: Who is responsible for purchased equipment installation and setup in each of UAT, Pilot, and Rollout phases?

Q2: Who is responsible for state office/clinic equipment procurement related to EBT services such as card readers?

Q3: Please confirm the EBT contractor is fully responsible for Retail Vendor (Lane) equipment.

Answer to question 78:

**(Q1) The State Agency**

**(Q2) The state will procure needed EBT equipment for the state office and local agencies (clinics).**

**(Q3) Confirmed**

Question 79: Task T.4.19 states the TIC will provide system hosting for UAT.

Q: Is this hosting part of the five (5) year hosting requested in the RFP?

Answer to question 79: **No. The 3-5 year hosting period requested begins after rollout. Task 4.19 refers to providing a test environment.**

Question 80: In the Description for T.4.19, there is a note that the vendor will provide a weekly support cost. There is not a deliverable associated with the weekly support cost.

Q1: What specific services are to be priced as part of the weekly support costs that would not be part of the base, fixed UAT support services?

Q2: Where and How in the response and cost Proposal (Appendix B) should this weekly support cost be documented?

Q3: Please explain how RI will exercise options for additional or less weekly support cost during UAT.

Answer to question 80:

**(Q1) On-site vs. off-site costs, in the event that we will need on-site support for fewer than the eight (8) weeks planned.**

**(Q2) Appendix B has been amended to include weekly support cost documentation.**

**(Q3) Will not be known until after UAT begins, at which point the State Agency could evaluate the time needed for on-site UAT support.**

Question 81: In the Description for T.4.21, there is mention of new releases for fixes.

Q1: What release frequency has the Crossroads M&E Contractor committed to during the Rhode Island UAT?

Q2: In the event that the Crossroads M&E Contractor cannot deliver working and acceptable releases to resolve reported defects within the UAT schedule, will RI be willing to delay the remainder of UAT as well as Pilot and Statewide implementation?

Answer to question 81:

**(Q1) During UAT, the Crossroads M&E contractor will be providing no new releases to RI. The design, configuration, UAT, Pilot and Rollout stages will all continue using whatever Crossroads version has been released at the start of the process. New releases developed for the User Group during RI WIC's Implementation will only be applied to RI WIC only after the rollout is completed, during the Hosting phase.**

**(Q2) No. In the unlikely event the current version of Crossroads (available at the start of the design/configuration stage) has reported defects, UAT will continue using what work-arounds are available. The M&E contractor will not address any defects for RI WIC during implementation.**

Question 82: Q: For Task T.5.4, is the expectation that TIC staff be physically present in clinic locations to perform the readiness tests?

Answer to question 82: **Yes**

Question 83: Q: For Task T.5.5, approximately how many state trainers and super users are anticipated to require training?

Answer to question 83: **15-20**

Question 84: Task T.5.7 appears to describe the Mock Clinic as occurring as a pre-training activity as opposed to being part of training.

Q1: Please confirm the scheduling and frequency of Mock Clinic.

Q2: Will state staff and UAT testers be the participants in the Mock Clinic as staff members?

Q3: Will Pilot clinic staff NOT be part of the Mock Clinic?

Q4: Will an actual (pilot) clinic location be available for the Mock Clinic activity?

Answer to question 84:

**(Q1) Will occur prior to Pilot, State Agency will schedule this later.**

**(Q2) Yes**

**(Q3) Clinic staff will not be in Mock Clinic, State Agency staff only.**

**(Q4) No**

Question 85: Task T.5.8 states that RI WIC may shorten the Pilot if it is going well and they feel comfortable moving up statewide rollout and they feel there are adequate resources to speed up the timeline.

Q1: Does the State have a preference for how accelerated statewide rollout will be?

Q2: What specific criteria has been identified by RI WIC to monitor in support of this decision?

Answer to question 85:

**(Q1) Accelerated rollout is a possibility, but it is assumed rollout will not be accelerated. Any possible accelerated rollout would be discussed and decided upon during Pilot.**

**(Q2) Specific criteria for this possibility has not been identified. This decision will be based on observations of the TIC, State Agency and QA contractor, and will be decided by the State Agency.**

Question 86: In the Description for T.5.8, there is a note that the vendor will provide a weekly support cost. There is not a deliverable associated with the weekly support cost.

Q1: What specific services are to be priced as part of the weekly support costs that would not be part of the base, fixed Pilot support services?

Q2: Where and How in the response and cost Proposal (Appendix B) should this weekly support cost be documented?

Q3: Please explain how RI will exercise options for additional or less weekly support cost during UAT-Pilot.

Answer to question 86:

**(Q1) On-site vs. off-site costs, in the event that we will need on-site support for fewer than the eight (8) weeks planned.**

**(Q2) Appendix B has been updated to allow weekly support cost documentation.**

**(Q3) Will not be known until after UAT begins, at which point the State Agency could evaluate the time needed for on-site Pilot support.**

Question 87: In the Description for T.5.11, there is mention of new releases for fixes.

Q: What release frequency has the Crossroads M&E Contractor committed to during the Rhode Island Pilot?

**Answer to question 87: During Pilot, the Crossroads M&E contractor will be providing no new releases to RI. The design, configuration, UAT, Pilot and Rollout stages will all continue using whatever Crossroads version has been released at the start of the process. New releases developed for the User Group during RI WIC's Implementation will only be applied to RI WIC only after the rollout is completed, during the Hosting phase.**

Question 88: In the Description of T.6.3, the statement is made that the TIC will be on site during the first week of Rollout. This task also requires the TIC to provide a plan for accomplishing this in their proposal.

Q1: Where is the TIC expected to be? In the State Office, at one clinic location, or at multiple clinic locations during the week?

Q2: Please clarify the task description as it references both Pilot and Rollout.

Q3: Please confirm that the required plan to be included in the Proposal is how the TIC intends to accomplish the three (3) phase rollout

Answer to question 88:

**(Q1) Primarily at the state office, though deployment to local agencies elsewhere in the state may occur as problems arise during Rollout. Due to the small size of Rhode Island, agencies are mostly accessible within a 45 minute drive from the State Office, so that staying in or near Providence for this period is feasible.**

**(Q2) After the completion of the 3-month Pilot phase, task T.6.3 commences. Reference to the Pilot in task T.6.3 is to clarify the order of events. The TIC will be on-site during the Pilot phase for other activities as well (Pilot initiation, training), but task T.6.3 refers to the Rollout phase.**

**(Q3) The three (3) phase rollout refers to three sets of local agency staff that will be trained consecutively, over the course of three (3) weeks. Proposal plans should include a Training Plan (and other associated plans) with the understanding that this is the established framework for rollout training.**

Question 89: In the Description of T.6.7, the statement is made that the TIC will be responsible for maintaining all hardware necessary to support the Crossroads system. It is unclear whether the hardware reference is to the server infrastructure, clinic equipment, or other.



Q1: Please clarify what hardware the TIC is responsible for maintaining.

Q2: Is hosting required and if so is this part of the 3-5 year hosting service that is required?

Answer to question 89:

**(Q1) Server equipment (if any).**

**(Q2) Hosting is required, yes this is part of the 3-5 year hosting service.**

Question 90: Task T.7.1 specifies six-month warranty however there is not explicit definition as to when the State requires warranty to start.

Q: When is the Six-Month Warranty expected to start and what is its schedule relationship with Closeout identified in the overall project schedule?

Answer to question 90: **The 6-month warranty period begins after the rollout has been completed.**

Question 91: Task T.7.3. states that in the event RI WIC selects an alternative hosting contractor, the TIC will provide a transition period following the initial contract and warranty period. This transition period will be negotiated as a separate task order under the existing contract.

Q: Under what conditions will there be procurement/selection of an alternative hosting contractor?

Q: When will the decision be made to seek an alternative hosting contractor?

Answer to question 91: **An alternative hosting contractor will be procured earlier than anticipated in the event that the TIC does not meet all contractual obligations or if RI WIC or the TIC decides to not exercise all renewal options for hosting. RI WIC will be minimally required to go out to procurement in Year 5 of the hosting contract due to the contract period of performance.**

Question 92: Q: What is the timeframe for providing User Group Coordination service identified in Task T.7.5?

Answer to question 92: **Throughout the 3-5 year hosting period.**

Question 93: Q: For D.1.4, please provide documentation about the state's existing telecommunications so that a draft Telecommunication Plan can be developed.

Answer to question 93: **The State's current vendor providing telecommunications support is Verizon, however the applicant must develop a telecommunications plan that will support any provider as connectivity will differ across the various local agency sites.**

Question 94: Q: Relates to D.2.3 – Please provide the current Requirements Traceability Matrix for the Crossroads system.

Answer to question 94: **Detailed specifications for the Crossroads system can be found by creating an account at <http://www.wictechnologypartners.com/>. Accounts require no special permissions or validations. Once logged in, click the “Resources” link on the home page, then “MIS Documentation”, then “Access Crossroads Support Documentation”.**

Question 95: Typically, the M&E Contractor is responsible for updating the system and user documentation for the SAM. Deliverable D.3.3 seems to imply that the TIC will be making or providing updates for documentation normally maintained by the M&E Contractor.

Q: Please clarify Crossroads system and user documentation responsibilities for the TIC.

Q: Does the State expect the TIC to create and maintain separate, RI-specific Crossroads documentation that will be separate from the standard Crossroads User Group documentation?

Answer to question 95:

**(Q1) RI-specific documentation will be necessary to account for RI-specific configurations, modules selected and what other design decisions are possible.**

**(Q2) The state expects the TIC to create and maintain separate, RI-specific documentation to account for RI-specific configurations, etc. These documents may be based on existing Crossroads documentation, with sections added to account for RI WIC’s specific choices for configuration, and with other sections removed that do not pertain to RI WIC (modules left out, etc).**

Question 96: The description of D.4.2 states that the TIC must certify that the system has successfully completed an end-to-end system test with “no deficiencies”.

Q: Please confirm that this means no deficiencies related to data conversion or configuration changes because those are the only two areas that the TIC can control.

Answer to question 96: **As the system’s host for RI, the TIC does have control over other aspects of the system. As the source code is not the responsibility of the TIC, any deficiencies may be addressed by the TIC (when possible) by identifying workarounds.**

Question 97: Deliverable D.6.2 states that the TIC will provide updates to “technical system documentation, interface source code, forms, or other materials that reflect the final implementation details...”. These are generally tasks of the M&E Contractor as part of the Crossroads change control/release process.

Q: Please clarify specifically what is expected in this deliverable if the TIC is not the Crossroads M&E Contractor.

Answer to question 97: **The state expects the TIC to create and maintain separate, RI-specific documentation to account for RI-specific configurations, etc. These documents may be based on existing Crossroads documentation, with sections added to account for RI WIC's specific choices for configuration, and with other sections removed that do not pertain to RI WIC (modules left out, etc).**

Question 98: Deliverable D.8.1 described as "See deliverables" in this phase 9 is not reflected in the Phase 8: Deliverables list.

Q1: Please provide a description for Deliverable D.8.1 as this deliverable is not included/described in the Phase 8: Deliverables list.

Q2: Please confirm that the tasks and deliverable D.8.1 in Phase 9 are Proposal response requirements only.

Q3: Where can the TIC perform project work? Are there any restrictions?

Answer to question 98:

**(Q1) See D.8.1**

**(Q2) This deliverable is for proposal response requirements as well as for the proposal of TIC team member replacements for core staff.**

**(Q3) Any tasks dealing with protected health information (PHI) cannot be performed outside of the USA. See Question 1.**

Question 99: Deliverable D.9.1 described as "See deliverables" in this phase 10 is not reflected in the Phase 8: Deliverables list.

Q: Please provide a description for Deliverable D.9.1 as this deliverable is not included/described in the Phase 8: Deliverables list. **See D.8.1**

Q: Please confirm that the tasks and deliverable D.9.1 in Phase 10 are Proposal response requirements only. **Confirmed**

Answer to question 99:

**(Q1) See D.8.1**

**(Q2) Confirmed**

(Question 100: Tasks T.9.1 and T.9.3 identify a requirement to include references in the proposal.

Q: What format and/or information does the State required for each reference?

Q: Are the references identified in Task T.9.1 different from the ones required by Task T.9.3?

Answer to question 100:

**(Q1) No special format is required, a signed letter with contact information is acceptable.**

**(Q2) Yes.**

Question 101: It is generally unclear when the described SLA tasks will become measurable for TIC performance EVAN

Q1: Which of the listed SLA tasks will apply and require measurement prior to UAT?

Q2: Which of the listed SLA tasks will apply and require measurement during UAT?

Q3: Which of the listed SLA tasks will apply and require measurement during Pilot?

Q4: Which of the listed SLA tasks will apply and require measurement during Rollout?

Q5: Which of the listed SLA tasks will apply and require measurement during the Phase 7 Maintenance & Operations period?

Answer to question 101:

**(Q1) None**

**(Q2) From UAT to (and after) Rollout: Tasks 10.2, 10.3, 10.7**

**(Q3) From Pilot to (and after) Rollout: Tasks 10.1, 10.4, 10.5, 10.8**

**(Q4) From (and after) Rollout: Task 10.6**

**(Q5) All SLA tasks will apply and require measurement during Phase 7.**

Question 102: The description for this phase states that the SLR's will be used to assess TIC performance throughout the contract period.

Q: Is the contract period referenced the transfer/implementation/warranty period or the 3-5 year hosting period?

Answer to question 102: **SLR-applicable period will be from the UAT period through the 3-5 year hosting period. See the answer to Question 101 above for specific SLR applicability during UAT/Pilot/Rollout.**

Question 103: Task T.10.2 references an Attachment 3.

Q: Can Attachment 3 be provided?

Answer to question 103: **Ready for distribution. See BUSINESS CAPACITY PLANNING STUDY.PDF**

Question 104: It is unclear within the scope of this project what tasks, deliverables, and service levels the Contractor is required to perform for the "Cultural and Linguistically Appropriate Services in Health Care".

Q: Please clarify the requirement as well as the time frame for performance.

Answer to question 104: **CLAS standards will not apply to the TIC, as they will not be working directly with clients.**

Question 105: Task T.10.7 states that RI WIC will not mediate issues between the eWIC and MIS systems.

Q: Please clarify RI WIC's involvement in situations where the issue involves services, decisions, or infrastructure provided by the State or when there is an impasse between the two vendors.

Answer to question 105: **In the event of a disagreement/impasse between the eWIC, TIC or QA, the State Agency will facilitate a final decision.**

Question 106: The applicant must prepare a separate, signed and sealed Cost Proposal using Appendix A – Cost Summary Form and Appendix B – Cost Worksheet for a 22-month term.

Appendix B is titled as "22-month budget"

Maintenance and Operations tasks, specifically hosting, has previously been described as a 3-5 year service. Some of the task requirements such as hosting may involve facility or non-hourly-based resources yet the cost worksheet appears to only allow for hourly services.

Q: Please clarify how vendors are to propose their 3-5 year hosting and support costs.

Q: Please clarify how vendors are to propose any non-hourly costs.

Q: Please clarify how vendors are to propose costs that are beyond the 22-month scope of the project.

Q: Please identify how and where the required weekly pricing is to be stated in Appendix A and Appendix B

Q: Please identify how many weeks of the required weekly pricing is to be included in the total project cost.

Answer to question 106: **Appendix B has been amended to allow for hosting/support costs. See revised appendix B.**

Question 107: The cost summary form states "It will also include the estimated cost to the HEALTH for any additional hardware or software needed by HEALTH to implement the Vendor's system. (These costs, though not part of the Vendor's Fixed Cost, shall be used in the evaluation of the proposed response). It shall also include costs for any options listed in this RFP."

There does not appear to be a phase or line on the summary or detailed cost forms for defining additional hardware or software costs or identifying options.

Q: Please clarify where in the cost proposal these additional costs are to be included.

**Answer to question 107: Any additional hardware/software costs should be added to the appropriate deliverable phase in Appendix A. A spreadsheet (for which there is no state template) should be included indicating what software/hardware is needed, the cost, the purpose (briefly) and to what phase those totals had been added.**

Question 108: The list for anticipated travel is different between Appendix A and B.

Q: Please confirm whether the list of anticipated travel in Appendix A or Appendix B is to be priced in both appendices.

Q: Please confirm that the prices for each of the project phases is to exclude travel.

**Answer to question 108: Travel costs are added to the Travel Cost section of Appendix B only.**

Question 109: Q: To what extent is the TIC expected to be onsite during the Mock Clinic activity that is scheduled prior to the Pilot Training?

**Answer to question 109: The TIC is not expected to be onsite during the Mock Clinic.**

Question 110: Phases 4 (Testing) and 5 (Pilot) require weekly pricing for onsite support. The cost proposal appendices do not appear to have a place for declaring the weekly pricing.

Q: Please identify how and where the required weekly pricing is to be stated in Appendix A and Appendix B

Q: Please identify how many weeks of the required weekly pricing is to be included in the total project cost.

**Answer to question 110: RI does not have a standard weekly pricing sheet. Weekly pricing information should include staff quantity, staff roles, and cost per week. Pilot = up to 8 weeks, UAT = up to 8 weeks. (other meetings/etc require travel but these are the only weekly on-site expenses asked for in phase 4)**

## Document Purpose

This document analyzes the ability of proposed new WIC System business partners to equal or exceed the capacity requirements and performance of the existing Rhode Island WIC System. (BCPS: Part A). The proposed WIC Systems for three vendors will be compared to the existing system evaluated in the baseline analysis of the existing system with regard to the following dimensions:

- An analysis of the database capacity and transaction volume;
- An analysis of the computational platform and processing requirements;
- An analysis of the hosting environment with regard to the availability, reliability and maintainability of the new MIS; and
- An assessment of the qualifications of staff needed to support and maintain the new MIS;
- An assessment of the potential impact on Rhode Island business partners of a new WIC Information System.

This BCPS: Part B specifically reviews proposed architectures, capacity and transaction volume when compared to the baseline system described in BCPS: Part A.

## Document Revision History

*Exhibit 1 Version Control Table*

Date	Version	Document Change	Responsible Party
September 26, 2016	1.0	Proposed Capacity Planning Study Draft	David P. Wesenberg
September 26, 2016	1.0.1	Review	Joanne E. Peterson
September 26, 2016	1.0.2	Review	David P. Wesenberg
October 14, 2016	2.0	Approved by client	Lauren Dalton

## Acronyms and Definitions

*Exhibit 2 Acronyms, Abbreviations and Definitions*

Acronym	Definition
BCPS	Business Capacity Planning Study
Cumulative % Distribution	A way of displaying a range of results as x% of data below a value (e.g. 90% below 20 seconds)
DOH	Department of Health

EBT/eWIC	Electronic Benefits Transfer
ESC	Executive Steering Committee
Entry Service Level	Cumulative % of Form Entry Times samples at 50% and 95%.
IAPD/APD	Implementation Advance Planning Document
FRD	Functional Requirements Document
FReD	USDA Functional Requirements Document
MIS	Management Information System
Query Service Level	Cumulative % of Query Time from push of button until reply
RI	Rhode Island
RIWEBS	Rhode Island's current WIC MIS
RFP	Request for Proposal
SOW	Statement of Work
T&I	Transfer and Implementation
USDA FNS	United States Department of Agriculture Food and Nutrition Services
Weibull Graph	A graph with a linear abscissa and an ordinate stepped off in units of sigma (Standard Deviation) with labeling as the percentage cumulative that sigma step-off represents
WIC	Special Supplemental Nutrition Program for Women, Infants, and Children



## Table of Contents

Document Purpose	1
Document Revision History	1
Acronyms and Definitions	1
Table of Contents	3
Table of Exhibits	3
Table of Equations	<b>Error! Bookmark not defined.</b>
Project Background and Objectives	4
Introduction	4
1.1 Purpose	4
1.2 Scope	5
1.3 References	5
1.4 Overview of Proposed Replacement WIC Systems	7
1.4.1 CMA Proposed System	8
1.4.2 CSC Proposed System	9
1.4.3 3Sigma Proposed System	11
1.4.4 Items Common to all proposers	13
1.5 Assumptions	13
1.5.1 Numbers from Documentation	13
3 Approach to Proposer Capacity Management	14
3.1 Service Level Calculation	14
4 Conclusions and Results	15

## Table of Exhibits

<i>Exhibit 1 Version Control Table</i> .....	1
<i>Exhibit 2 Acronyms, Abbreviations and Definitions</i> .....	1
<i>Exhibit 3 List of Document References</i> .....	5
<i>Exhibit 4 Current Rhode Island Configuration</i> .....	7

## **Project Background and Objectives**

The Rhode Island (RI) Department of Health (DOH) contracted with MAXIMUS, a planning contractor, to assist the RI Women, Infants, and Children (WIC) Program with planning to replace its current Management Information System (MIS) RIWEBS with a web based eWIC functional MIS system. MAXIMUS will support RI WIC by overseeing the initial MIS planning process, supplying a clinic flow analysis, completing a Feasibility Study, developing a combined eWIC/MIS Implementation Advance Planning Document (IAPD) and providing a Transfer and Implementation (T&I) Request for Proposals (RFP) to be used for an implementation Statement of Work (SOW).

The objective of this planning project is to position the RI WIC Program to begin the transfer and implementation of an MIS and eWIC system. Following the planning phase, the RI WIC Program will be adequately equipped with the information and resources it requires to move forward with successful eWIC acquisition and implementation, building on lessons learned from other States who have already successfully transitioned to eWIC.

## **Introduction**

The State of Rhode Island (the State) has decided to replace its existing Women, Infants and Children (WIC) Food and Nutrition Service Support Application due to its outdated and unsupported technology. The current Management Information System (MIS) known as RIWEBS has successfully met the needs of the RI WIC Program. Any replacement for the WIC System must perform at least at the same level as the existing system and fully implement the current requirements of the WIC Program.

### **1.1 Purpose**

The purpose of this Business Capacity Planning Study (BCPS: Part B) is to evaluate proposed replacement systems for WIC Food and Nutrition Service Support against the baseline for the existing outdated system. This capacity must include all quantitative aspects of capacity in a form that can be compared to the existing system to achieve the same or better performance.

## 1.2 Scope

As stated in the RFP, the BCPS will include:

- An analysis of the database capacity and transaction volume;
- An analysis of the computational platform and processing requirements;
- An analysis of the hosting environment with regard to the availability, reliability and maintainability of the new MIS; and
- An assessment of the qualifications of staff needed to support and maintain the new MIS;
- An assessment of the potential impact on Rhode Island business partners of a new WIC Information System.

Part B will specifically include:

- An analysis of the proposed replacement systems’ database capacities and transaction volumes;
- An analysis of the proposed replacement systems’ platforms and processing requirements; and
- An analysis of the proposed replacement systems with regard to the availability, reliability and maintainability of RIWEBS.

## 1.3 References

The table below lists the documents provided by the State to complete the BCPS: Part A analysis.

*Exhibit 3 List of Document References*

Name	Description
<b>Capacity Planning SOW</b>	Statement of Work pertaining to this Capacity Study
<b>Abator MIS Questions</b>	Answers to questions posed by Abator personnel to acquire information for this study
<b>FReD v2.0 Final Specification</b>	WIC Specification for WIC Information System
<b>Clinic Site Visit</b>	Plan for Site Visit
<b>Current Technical Environment</b>	Business Environment Questions to State
<b>Functional Requirements State Evaluation</b>	Environment Questions for State
<b>CSC RIWEBS Hosting</b>	Description of RIWEBS WIC Configuration
<b>Latest WIC Computer Inventory</b>	List of all Workstations used at RI WIC
<b>RIWEBS Recovery Data Plan</b>	Disaster Recovery Planning
<b>Results of Site Visits</b>	Newport and Woonsocket Measurements
<b>Business Capacity Planning Part A</b>	Capacity of the existing baseline system used as a basis of comparison for proposed replacement systems.

Name	Description
<b>Crossroads Developer Questionnaire</b>	CSC Responses and marketing in response to questionnaire
<b>RI Developer Questionnaire Results – V 1.1</b>	Compiled responses to questionnaire compared by question.
<b>Survey Analysis</b>	Comparison of claims by proposed vendors of replacement system.

## 1.4 Overview of Proposed Replacement WIC Systems

For the purposes of this BCPS the following baseline model will be used.

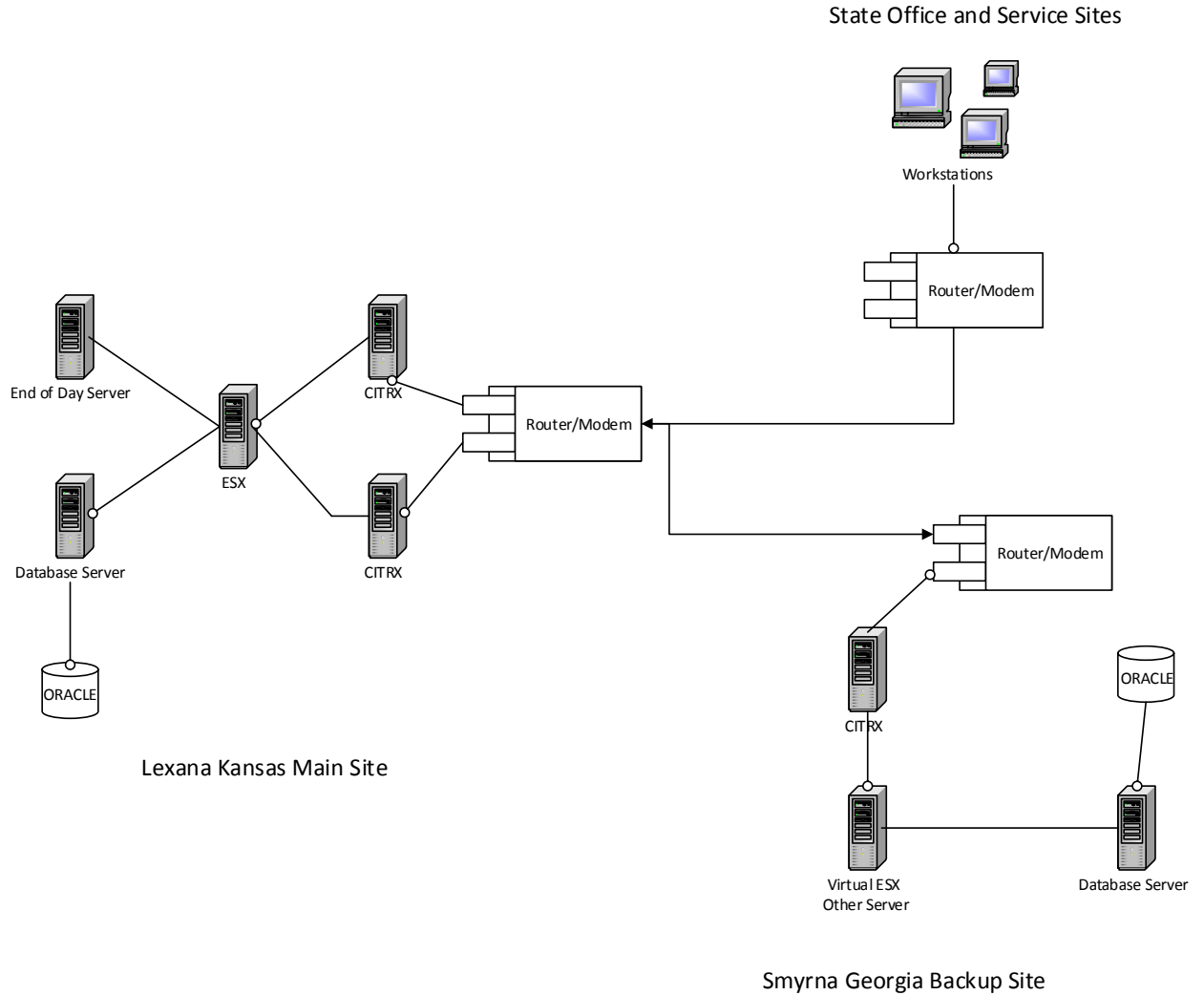

*Exhibit 4 Current Rhode Island Configuration*

Comparison of the three proposed replacement WIC Systems by the vendors CMA, CSC and 3Sigma will reveal whether the same considerations were addressed as in the baseline system.

## 1.4.1 CMA Proposed System

### 1.4.1.1 Network Speed

According to the statistics provided by CMA, 98% of the service calls to their site’s interface take place in less than 1 second and 99.7% in less than 2 seconds. These figures do not take into consideration the network transport time from and to the WIC Service Site.

The difference from the baseline site at between 98% and 99.7% (taking into account the provided data is extended beyond supporting data in Appendix B of Part A of this study which includes networking transit time) there is a second or so difference at 98% without networking. Assuming that 50% is about half of this or 0.6 seconds, then the 90% span of CMA without networking is 0.6 seconds. The 90% span of the baseline with networking is 1.3 seconds. This leaves a residual of 0.7 seconds for the networking only as a crude approximation.

This means that on average, if added to the base mean for CMA of 0.6 seconds, half the network variance for the baseline of 0.35 plus half the CMA variance of 0.3, there is a 95% value of 1.25 seconds. To this add 0.35 network average from the CSC calculation below. This nets 95% below 1.9 seconds for query response. These are estimates, but the crude results are:

Cumulative Percent	Baseline	CMA
50%	1.0 seconds	1.0 seconds
90%	1.5 seconds	1.6 seconds
99%	1.6 seconds	1.9 seconds

### 1.4.1.2 Form Entry

CMA provided no data for comparison as requested.

### 1.4.1.3 Database Capacity and Transactions

CMA currently handles 30 times the Rhode Island WIC caseload so Rhode Island represents about 3% of the storage deployed. No database raw storage capacity problems are expected. The transactional volume is addressed in the above query turnaround calculations and appears to pose no problem.

### 1.4.1.4 Production Environment

The recommended server environment from BCPS: Part A is as follows.

Server	Configuration	Software
One – Batch Processing Server	Single Xeon Dual Core, 8 GB RAM, 2 X 250 GB HDD (Mirror) Virtual	Windows 2012R2 Standard Edition
Two - IIS	Single Xeon Dual Core, 16GB RAM, 2 X 250 GB HDD (Mirror) Virtual Separate Servers	Windows 2012R2 Web Edition
One - Database Server	Dual, Dual Core, 16 GB RAM, 3X 500 GB HDD (RAID 5) Virtual	Windows 2012R2 Enterprise Edition

CMA uses VM Technology and should be able to implement this configuration. They use ORACLE® and do not recommend RAC Clustering feeling it is unnecessary. However, if a hot backup database at a different location is required they will have to ship the transaction files as transactions occur to a remote backup database site and RAC may be the most configurable way to do it. ORACLE® recommends a RAID10 configuration for the disks for RAC.

It may be necessary to allocate more processors and memory to the database server as ORACLE® is heavy user of resources. CMA appears to be able to act flexibly and with scalability to adjust to any foreseeable load.

From what the author was able to discern, CMA’s Data Center is managed by the University of Arizona IT Department and has only one location. It is capable of expanding resources in a flexible, scalable manner, but may not be able to maintain service if a local negative events brings their facility down.

## 1.4.2 CSC Proposed System

### 1.4.2.1 Network Speed

The figures for CSC with networking which compared to the baseline are

Cumulative Percent	Baseline	CSC
50%	1.0 seconds	1.2 seconds
90%	1.5 seconds	1.6 seconds
99%	1.6 seconds	2.1 seconds

Using calculations similar to that for CMA, there is a 90% span for CSC of 0.5 seconds about a 50% mean of 0.55 seconds. Applying the same comparison, CSC results in a 95% Query Response Level of 1.45 seconds, better than both CMA and the baseline. From the above actual measurement it is necessary to add about 0.35 seconds to account for average net transfer time. The variances are similar.

Other data was provided by CSC which upon cursory examination showed query response data roughly equivalent to this. CSC has a query response slightly slower than the baseline, but well within specification of 5 seconds. Since the query response represents only about 9% of form turn around this will not materially affect productivity, and as discussed in the next section, CSC forms are apparently easier and faster to enter.

**1.4.2.2 Entry Speed**

CSC form entry speed is as follows.

<b>Cumulative Percent</b>	<b>Baseline</b>	<b>CSC</b>
50%	20 seconds	11 seconds
90%	34 seconds	14 seconds
99%	138 seconds	18 seconds

Considering form entry and query time combined, CSC forms are roughly twice as fast to enter at the 90% level.

**1.4.2.3 Database Capacity and Transactions**

CSC currently handles about 12.5 times the WIC Case Load processed by Rhode Island. There should be no database storage challenges. Transactional volume combined with simpler forms should increase entry productivity substantially.

**1.4.2.4 Production Environment**

CSC proposes a cloud based virtual processing environment to implement the suggested framework below.

However, they are suggesting that only one application server and one database server may be enough to support Rhode Island WIC at normal loading. CSC suggests adding on additional resources only if needed for peak loads.

Again we use the following baseline for purposes of comparison.



Server	Configuration	Software
One – Batch Processing Server	Single Xeon Dual Core, 8 GB RAM, 2 X 250 GB HDD (Mirror) Virtual	Windows 2012R2 Standard Edition
Two - IIS	Single Xeon Dual Core, 16GB RAM, 2 X 250 GB HDD (Mirror) Virtual Separate Servers	Windows 2012R2 Web Edition
One - Database Server	Dual, Dual Core, 16 GB RAM, 3X 500 GB HDD (RAID 5) Virtual	Windows 2012R2 Enterprise Edition

CSC has redundant database servers but it is not clear whether these servers are located at different locations. Recommend clarification, because vendors should be able to counter the possibility of a weather or flooding disaster at one location by switching to another.

### 1.4.3 3Sigma Proposed System

#### 1.4.3.1 Network Speed

The following are the query service level figures for 3Sigma.

Cumulative Percent	Baseline	3S
50%	1.0 seconds	1.3 seconds
90%	1.5 seconds	1.9 seconds
99%	1.6 seconds	2.3 seconds

**1.4.3.2 Entry Speed**

<b>Cumulative Percent</b>	<b>Baseline</b>	<b>3S</b>
50%	20 seconds	17 seconds
90%	34 seconds	19 seconds
99%	138 seconds	23 seconds

The 3Sigma solution is much faster than the existing system and a little slower than CSC.

**1.4.3.3 Database Capacity and Transactions**

No data was provided. It appears 3Sigma has not been able to measure production volumes yet.

3Sigma is using optimized ORACLE® Stored Procedures which separates the data acquisition layer from the business logic. 3Sigma’s claim of simpler database structure and greater network response is probably valid and more secure as well. Pre-compilation does substantially increase transactional speed.

**1.4.3.4 Production Environment**

3Sigma uses a virtual machine environment and are proposing 6 servers be created for Rhode Island WIC.

The baseline configuration was used for purposes of comparison.

Server	Configuration	Software
One – Batch Processing Server	Single Xeon Dual Core, 8 GB RAM, 2 X 250 GB HDD (Mirror) Virtual	Windows 2012R2 Standard Edition
Two - IIS	Single Xeon Dual Core, 16GB RAM, 2 X 250 GB HDD (Mirror)Virtual Separate Servers	Windows 2012R2 Web Edition
One - Database Server	Dual, Dual Core, 16 GB RAM, 3X 500 GB HDD (RAID 5) Virtual	Windows 2012R2 Enterprise Edition

The one exception is that 3Sigma will use an ORACLE® Database Appliance that is 500 times larger than needed by just Rhode Island. However, this server is apparently not redundant to multiple locations so if it fails, the WIC System fails. Recommend clarification, because vendors should be able to counter the possibility of a weather or flooding disaster at one location by switching to another.

#### 1.4.4 Items Common to All Proposers

Basic assumptions concerning volumes shown in BCPS: Part A are not repeated here as they have not changed. This includes assumptions in Section 2.5 of that document and Sections 7 and 8 from that document that discuss Test Environments and Desktop Environments.

It appears that test environments are virtual and produced as needed by all proposers.

The desktop environment should be upgraded to Windows 10, especially for the graphic environment proposed by CSC Crosstalk. This was recommended and may have already occurred.

### 1.5 Assumptions

Using the documentation provided by the State and measurements taken while onsite, the following additional assumptions were used for this assessment:

#### 1.5.1 Numbers from Documentation

- 1.23 Transactions/Second at servers
- Maximum CPU burden of Database Server 45% of Dual Processor
- Average CPU Burden of Database Server 5%

- RAID5 Storage of main database
- 96 Workstations interact with servers
- Backup Site planned for 70% of Main Site Load
- Database is 24 GB
- Growth is proportional to population (65% use WIC) which is 0.35%/year according to US Census from 2010 to 2015,
- Database Full Backup is 14 GB
- Woonsocket has 8 entry workstations
- Newport has 3 entry workstations

### 3 Approach to Proposer Capacity Management

The analytical details have not changed, but the approach assumes it is sufficient to demonstrate whether the proposed system meets or exceeds the baseline system described in BCPS: Part A. The service level calculations are repeated here because they are used here, but they were not graphed. It was possible to see whether they better than the baseline directly from the data once the Bernard Approximation was used on the ordered data, which compared 13, 15 or 16 sample cumulative distributions.

No additional work was done on the Work Station Environment because it appeared to be baselined with more than enough capacity to handle the Rhode Island WIC Transaction Volume.

#### 3.1 Service Level Calculation

The Service Level was determined by using Bernard's Approximation for calculating the Median Probability Ranks which is

*Equation 1 Bernard's Approximation for Median Probability Rank*

$$MR = (j - 0.3)/(N + 0.4)$$

Where  $N$  is the number of measurements

And  $j$  is the ordered rank from 1 (lowest) to  $N$  (highest).

The measurements are plotted against the Median Ranks on Weibull Standard Probability Graphs and the Service Level values were interpolated from the graph.

These measurements can be easily repeated on prospective replacement systems to determine if Service Levels are the same or better than the existing system for entry and query response.

Determining the network load entails assuming a no-load ping time for transmittal of a fairly standard 1500 byte packet within the median Service Level Query Time. This assessment

assumes a ping time of 80 milliseconds in this case. This allows for determination of how big the query and its response is in bytes from the Service Level Time. The result can then project that figure at high service query loading.

## **4 Conclusions and Results**

Any of the proposers would be able to meet the standard of meeting or exceeding the baseline. The baseline had a little faster query service level for some, but the faster forms entry would improve productivity substantially more than anything lost in query response.

From the standpoint of configuration for maintainability and reliability the only flaw noted is if multiple locations are not used to provide for backup response if some weather or geographic disaster strikes. From a maintainability standpoint modern cloud based and virtual environments provide a lot more redundancy and flexibility to configure when load or conditions change.

Reliability has improved since the baseline system was deployed as well, but there still remains some failure modes such as a data center catastrophe, network interruption or power interruption that could stop the Rhode Island WIC System.

Given this possibility, there should be a remote backup system and remote backup storage media.

**ADDENDA**

Attached hereto, incorporated into and made a part herein of this agreement, are the following addenda:

- ADDENDUM I - Scope of Work
- ADDENDUM II - Budget
- ADDENDUM III - Payments and Reports Schedule
- ADDENDUM IV - Fiscal Assurances
- ADDENDUM V - Notice to Rhode Island Department of Health’s Service Providers of Their Responsibilities Under Title VI of The Civil Rights Act of 1964
- ADDENDUM VI - Notice to Rhode Island Department of Health’s Service Providers of Their Responsibilities Under Section 504 of the Rehabilitation Act of 1973
- ADDENDUM VII - Drug-Free Workplace Policy
- ADDENDUM VIII - Drug Free Workplace Policy Contractor Certificate of Compliance
- ADDENDUM IX - Subcontractor Compliance
- ADDENDUM X - Certification Regarding Environmental Tobacco Smoke
- ADDENDUM XI - Instructions for Certification Regarding Debarment, Suspension and Other Responsibility Matters – Primary Covered Transactions
- ADDENDUM XII - Certification Regarding Debarment, Suspension and Other Responsibility Matters – Primary Covered Transactions
- ADDENDUM XIII - Liquidated Damages
- ADDENDUM XIV - Equal Employment Opportunity
- ADDENDUM XV - Byrd Anti-Lobbying Amendment
- ADDENDUM XVI - Bid Proposal
- ADDENDUM XVII - Core Staff Positions
- ADDENDUM XVIII - Business Associate Agreement **DELETE IF NOT NEEDED**

## ADDENDUM I

### SCOPE OF WORK

Agency Name

“Title of Agreement”

Contract Period

### CLAS Language

#### INCLUDE IF USING FEDERAL \$

#### **Cultural Competence**

Cultural competence is the integration and transformation of knowledge about individuals and groups of people into specific standards, policies, practices and attitudes used in appropriate cultural settings to increase the quality of services, thereby producing better outcomes. Competence in cross-cultural functioning means learning new patterns of behavior and effectively applying them in appropriate settings.

#### **Limited English Proficiency**

Under the authority of Title VI of the Civil Rights Act of 1964, Presidential Executive Order No. 13166 requires that recipients of federal financial assistance ensure meaningful access by persons with limited English proficiency (LEP) to their programs and activities. A 2002 report from the U.S. Department of Justice, *Prohibition Against National Origin Discrimination Affecting Limited English Proficient Persons*, provides guidance on uniform policies for all federal agencies to implement Executive Order No. 13166. Further, the National Standards for Culturally and Linguistically Appropriate Services in Health Care (CLAS Standards) issued by the Federal Office of Minority Health in 2004 outline mandates, guidelines, and a recommendation for the provision of language access services, culturally competent care, and organizational supports for cultural competence in health care settings. CLAS Standards 4-7 (see below) are mandates and address language access services that should be provided by every organization that receives federal funding, whether directly or indirectly.

Effective immediately, all vendors who contract with RIDOH must perform the following tasks and provide documentation of such tasks upon request of a RIDOH employee:

1. The supports and services provided by vendor shall demonstrate a commitment to linguistic and cultural competence that ensures access and meaningful participation for all people in the service area or target population. Such commitment includes acceptance and respect for cultural values, beliefs and practices of the community, as well as the ability to apply an understanding of the relationships of language and culture

to the delivery of supports and services. Vendor shall have an education, training and staff development plan for assuring culturally and linguistically appropriate service delivery.

2. Vendor shall have a comprehensive cultural competency plan that addresses the following: 1) the identification and assessment of the cultural needs of potential and active clients served, 2) sufficient policies and procedures to reflect the agency's value and practice expectations, 3) a method of service assessment and monitoring, and 4) ongoing training to assure that staff are aware of and able to effectively implement policies.
3. Vendor shall have a plan to recruit, retain and promote a diverse staff and leadership team, including Board members, representative of the demographic characteristics of the populations served.
4. Vendor shall assure equal access for people with diverse cultural backgrounds and/or limited English proficiency, as outlined by the Department of Justice, *Prohibition Against National Origin Discrimination Affecting Limited English Proficient Persons*. Vendor shall provide language assistance services (i.e. interpretation and translation) and interpreters for the deaf and hard of hearing at no cost to the client.

## **National Standards for Culturally and Linguistically Appropriate Services in Health Care**

### **Culturally Competent Care (Standards 1-3)**

#### **Standard 1**

Health care organizations should ensure that patients/consumers receive from all staff member's effective, understandable, and respectful care that is provided in a manner compatible with their cultural health beliefs and practices and preferred language.

#### **Standard 2**

Health care organizations should implement strategies to recruit, retain, and promote at all levels of the organization a diverse staff and leadership that are representative of the demographic characteristics of the service area.

#### **Standard 3**

Health care organizations should ensure that staff at all levels and across all disciplines receive ongoing education and training in culturally and linguistically appropriate service delivery.

### **Language Access Services (Standards 4-7)**

#### **Standard 4\***

Health care organizations must offer and provide language assistance services, including bilingual staff and interpreter services, at no cost to each patient/consumer with limited English proficiency at all points of contact, in a timely manner during all hours of operation.

#### **Standard 5\***

Health care organizations must provide to patients/consumers in their preferred language both verbal offers and written notices informing them of their right to receive language assistance services.

#### **Standard 6\***

Health care organizations must assure the competence of language assistance provided to limited English proficient patients/consumers by interpreters and bilingual staff. Family and friends should not be used to provide interpretation services (except on request by the patient/consumer).

#### **Standard 7\***

Health care organizations must make available easily understood patient-related materials and post signage in the languages of the commonly encountered groups and/or groups represented in the service area.



## **Organizational Supports for Cultural Competence (Standards 8-14)**

### **Standard 8**

Health care organizations should develop, implement, and promote a written strategic plan that outlines clear goals, policies, operational plans, and management accountability/oversight mechanisms to provide culturally and linguistically appropriate services.

### **Standard 9**

Health care organizations should conduct initial and ongoing organizational self-assessments of CLAS-related activities and are encouraged to integrate cultural and linguistic competence-related measures into their internal audits, performance improvement programs, patient satisfaction assessments, and outcomes-based evaluations.

### **Standard 10**

Health care organizations should ensure that data on the individual patient's/consumer's race, ethnicity, and spoken and written language are collected in health records, integrated into the organization's management information systems, and periodically updated.

### **Standard 11**

Health care organizations should maintain a current demographic, cultural, and epidemiological profile of the community as well as a needs assessment to accurately plan for and implement services that respond to the cultural and linguistic characteristics of the service area.

### **Standard 12**

Health care organizations should develop participatory, collaborative partnerships with communities and utilize a variety of formal and informal mechanisms to facilitate community and patient/consumer involvement in designing and implementing CLAS-related activities.

### **Standard 13**

Health care organizations should ensure that conflict and grievance resolution processes are culturally and linguistically sensitive and capable of identifying, preventing, and resolving cross-cultural conflicts or complaints by patients/consumers.

### **Standard 14**

Health care organizations are encouraged to regularly make available to the public information about their progress and successful innovations in implementing the CLAS standards and to provide public notice in their communities about the availability of this information.

### **\* Mandates**

11-28-11

**ADDENDUM II**

**BUDGET**

Agency Name  
"Title of Agreement"  
Contract Period

The Contractor estimates that the budget for allowable expenses for work to be performed under this Agreement is as follows:

Expense Category	Contract Period
1. Personnel	\$0
2. Fringe Benefits	\$0
3. Consultants	\$0
4. In-State Travel	\$0
5. Out-of-State Travel	\$0
6. Printing / Copying	\$0
7. Supplies	\$0
8. Resource Materials	\$0
9. Telephone	\$0
10. Equipment	\$0
11. Postage	\$0
12. Subcontracts	\$0
13. Other	\$0
Indirect Cost	\$0
<b>TOTAL:</b>	<b>\$0</b>

It is understood and agreed that the amounts indicated above for the several line items are estimates of expenditures to be incurred by the Contractor on behalf of this Agreement and to be claimed by the Contractor for reimbursement under this Agreement. It is further understood and agreed that actual variations shall not in themselves be cause for disallowance of reimbursement by RIDOH; provided, however, that the Contractor shall notify and obtain the approval of the contract officer, in writing, if expenditures to be claimed for reimbursement in any line item above shall begin to vary significantly from the estimate given above; and provided further, that unless permission of the contract officer shall have been obtained in advance, no expenditure shall be claimed by the Contractor for reimbursement by RIDOH under this Agreement if such expenditure shall have been incurred in a line item category not listed above. Transfer of funds is permitted between Expense Categories (1), (2), and (3); all other transfers require prior written approval by the Department of Health.

**BUDGET JUSTIFICATION**

Agency Name

"Title of Agreement"

Contract Period

<b>PERSONNEL</b>	<b>\$0</b>
<b>FRINGE BENEFITS</b>	<b>\$0</b>
<b>CONSULTANTS</b>	<b>\$0</b>
<b>IN-STATE-TRAVEL</b>	<b>\$0</b>
<b>OUT-OF STATE TRAVEL</b>	<b>\$0</b>
<b>PRINTING / COPYING</b>	<b>\$0</b>
<b>SUPPLIES</b>	<b>\$0</b>
<b>RESOURCE MATERIALS</b>	<b>\$0</b>
<b>TELEPHONE</b>	<b>\$0</b>
<b>EQUIPMENT</b>	<b>\$0</b>
<b>POSTAGE</b>	<b>\$0</b>
<b>SUBCONTRACT</b>	<b>\$0</b>
<b>OTHER</b>	<b>\$0</b>
<b>INDIRECT COST</b>	<b>\$0</b>
<b>TOTAL AWARD</b>	<b><u>\$0</u></b>

**Total in-kind Contribution - \$0**

**ADDENDUM III**  
**PAYMENTS AND REPORTS SCHEDULE**

**Request for Reimbursement**

- Before payments are processed, agency invoices will be reviewed to insure that all allowable costs are appropriately documented. All invoices will be reviewed to prevent deviation from approved contract budgets.
- Agencies will be paid based on actual expenditures and will be reimbursed on a monthly basis.
- Invoices must be submitted to the RIDOH Project Officer by the 10<sup>th</sup> of the month following the reporting period.
- Agencies will include the following required documentation as an attachment to submitted invoice:  
**(MODIFY TO MIRROR CONTRACT)**
  - Name of employee, title, hours worked, rate of pay
  - Consultant copies of bills submitted (must include rate of pay and number of hours)
  - In-state mileage - rate per mile (as indicated in contract) including number of miles
  - Out-of state mileage - Copy of receipts for all travel related expenses; e.g., travel itinerary, hotel detail bill, parking, taxi & shuttle receipts. Air Travel: include a copy of the boarding pass & receipt. Train Travel: copy of ticket and receipt. No documentation is necessary for per diem expenses, which include meals and incidentals capped at \$30 per day.
  - Copy of all receipts (i.e.; supply purchases, telephone document of expense, etc.)
- Request for Reimbursements that are completed incorrectly will be returned to the Agency Project Coordinator for corrections.
- **Prior written approval** from the RIDOH Project Officer must be obtained before variations in the budget line item can be made. The Agency Project Director must submit requests in writing to the RIDOH Project Officer. Failure to have written approval for line item changes will result in non-reimbursement of expenditures.

**Reporting Requirements (INCLUDE AND CHANGE TO INFORMATION PROVIDED BY PROGRAM MANAGER)**

- **Monthly Reporting**
  - All monthly reports must be submitted to RIDOH Contract Officer by the 10<sup>th</sup> of the month following the reporting period through RIDOH identified reporting systems and forms. All forms associated with reporting information in the system will be provided by RIDOH.
- **Evaluation of CDC - Funded Health Department HIV Prevention Programs**
  - Funded agencies will be expected to comply with reporting and evaluation activities associated with this mandate including the following:
    - ✦ The Agency Project Staff will attend trainings associated with the evaluation of their project.
    - ✦ The Agency Project Staff will submit data reports on project participants using a reporting system specified by RIDOH.
    - ✦ The Agency Project Staff will cooperate with RIDOH on evaluation activities.
    - ✦ RIDOH will provide technical assistance and support to Agency Project Staff on the evaluation of the project as needed.
- **Project Written Report**
  - A semi-annual and year-end written project report must be submitted to RIDOH for each year the project is funded. The report format will be determined by RIDOH.

**ADDENDUM IV  
FISCAL ASSURANCES**

1. The Contractor agrees to segregate all receipts and disbursements pertaining to this agreement from recipients and disbursements from all other sources, whether by separate accounts or by utilizing a fiscal code system.
2. The Contractor assures a system of adequate internal control will be implemented to ensure a separation of duties in all cash transactions.
3. The Contractor assures the existence of an audit trail which includes: cancelled checks, voucher authorization, invoices, receiving reports, and time distribution reports.
4. The Contractor assures a separate subsidiary ledger of equipment and property will be maintained.
5. The Contractor agrees any unexpended funds from this agreement are to be returned to RIDOH at the end of the time of performance unless RIDOH gives written consent for their retention.
6. The Contractor assures insurance coverage is in effect in the following categories: bonding, vehicles, fire and theft, and liability.
7. The following Federal requirements shall apply pursuant to OMB Guidance for Grants and Agreements. Where applicable:
  - Subpart A - Acronyms and Definitions (200.0 – 200.99)
  - Subpart B – General Provisions (200.100 – 200.113)
  - Subpart C – Pre-Federal Award Requirements and Contents of Federal Awards (200.200 – 200.211)
  - Subpart D – Post Federal Award (200.300 – 200.345)
  - Subpart E – Cost Principles (200.400 – 200.475)
  - Subpart F – Audit Requirements(200.500 – 200.521)
  - All Subsequent Addenda
8. If the Contractor expends Federal awards during the Contractor's particular fiscal year of \$750,000 or more, then 2 CFR § 200.500 et. seq., audits of states, local governments and non-profit organizations shall also apply or if applicable, an audit shall be performed in accordance with "Government Auditing Standards" as published by the Comptroller General of the United States (see Paragraph 24).
9. This agreement may be funded in whole or in part with Federal funds. If so, the CFDA reference number is [93.270](#). The Contractor must review applicable Federal Statutes, regulations, terms and conditions of the Federal Award in accordance with 2 CFR § 200.331 (a)(2).

## ADDENDUM V

### RHODE ISLAND DEPARTMENT OF HEALTH

#### NOTICE TO RHODE ISLAND DEPARTMENT OF HEALTH'S SERVICE PROVIDERS OF THEIR RESPONSIBILITIES UNDER TITLE VI OF THE CIVIL RIGHTS ACT OF 1964

Public and private agencies, organizations, institutions, and persons that receive Federal financial assistance through the RI Department of Health (RIDOH) are subject to the provisions of Title VI of the Civil Rights Act of 1964 and the implementing regulations of the United States Department of Health And Human Services (DHHS), which is located at 45 CFR, Part 80, collectively referred to hereinafter as Title VI. RIDOH contracts with Contractors include a Contractor's assurance that in compliance with Title VI and the implementing regulations, no person shall be excluded from participation in, denied the benefits of, or be otherwise subjected to discrimination in its programs and activities on the grounds of race, color, or national origin. Additional DHHS guidance is located at 68 FR 47311-02.

RIDOH reserves its right to at any time review Contractors to assure that they are complying with these requirements. Further, RIDOH reserves its right to at any time require from Contractors, Sub-Contractors and Vendors that they are also complying with Title VI.

The Contractor shall have policies and procedures in effect, including, a mandatory written compliance plan, which are designed to assure compliance with Title VI. An electronic copy of the service providers written compliance plan and all relevant policies, procedures, workflows and relevant chart of responsible personnel must be available to RIDOH upon request.

The Contractor's written compliance plan must address the following requirements:

- Written policies, procedures and standards of conduct that articulate the organization's commitment to comply with all Title VI standards.
- Designation of a compliance officer who is accountable to the service provider's senior management.
- Effective training and education for the compliance officer and the organization's employees.
- Enforcement of standards through well-publicized guidelines.
- Provision for internal monitoring and auditing.
- Written complaint procedures
- Provision for prompt response to all complaints, detected offenses or lapses, and for development and implementation of corrective action initiatives.
- Provision that all Contractors, Sub-Contractors and Vendors of the service provider execute assurances that said Contractors, Sub-Contractors and Vendors are in compliance with Title VI.

The Contractor must enter into an agreement with each Sub-Contractor or Vendor under which there is the provision to furnish to it, DHHS or RIDOH on request full and complete information related to Title VI compliance.

The Contractor must submit, within thirty-five (35) days of the date of a request by DHHS or RIDOH, full and complete information on Title VI compliance by the Contractor and/or any Sub-Contractor or Vendor of the Contractor.

It is the responsibility of each Contractor to acquaint itself with all of the provisions of the Title VI regulations. A copy of the regulations is available upon request from the community relations liaison officer, **RI Department of Health, 3 Capitol Hill Providence, RI 02908-5097 Tel: (401) 222-5960.**

**THE REGULATIONS ADDRESS THE FOLLOWING TOPICS:**

**SECTION:**

80.1	Purpose
80.2	Application of This Regulation
80.3	Discrimination Prohibited
80.4	Assurances Required
80.5	Illustrative Application
80.6	Compliance Information
80.7	Conduct of Investigations
80.8	Procedure for Effecting Compliance
80.9	Hearings
80.10	Decisions and Notices
80.11	Judicial Review
80.12	Effect on Other Regulations; Forms And Instructions
80.13	Definition

## ADDENDUM VI

### RHODE ISLAND DEPARTMENT OF HEALTH

#### **NOTICE TO RHODE ISLAND DEPARTMENT OF HEALTH'S CONTRACTORS OF THEIR RESPONSIBILITIES UNDER SECTION USC 504 OF THE REHABILITATION ACT OF 1973**

Public and private agencies, organizations, institutions, and persons that receive Federal financial assistance through the **RI Department of Health (RIDOH)** are subject to the provisions of Section 504 of the Rehabilitation Act of 1973 and the Implementing Regulations of the United States Department of Health And Human Services (DHHS), which are located at 45 CFR, part 84 hereinafter collectively referred to as Section 504. RIDOH contracts with service providers include the provider's assurance that it will comply with Section 504 of the regulations, which prohibits discrimination against handicapped persons in providing health, welfare, or other social services or benefits.

The Contractor shall have policies and procedures in effect, including, a mandatory written compliance plan, which are designed to assure compliance with Section 504. An electronic copy of the Contractor's written compliance plan and all relevant policies, procedures, workflows and relevant chart of responsible personnel must be available to RIDOH upon request.

The Contractor's written compliance plan must address the following requirements:

- Written policies, procedures and standards of conduct that articulate the organization's commitment to comply with all Section 504 standards.
- Designation of a compliance officer who is accountable to the service provider's senior management.
- Effective training and education for the compliance officer and the organization's employees.
- Enforcement of standards through well-publicized guidelines.
- Provision for internal monitoring and auditing.
- Written complaint procedures
- Provision for prompt response to all complaints, detected offenses or lapses, and for development and implementation of corrective action initiatives.
- Provision that all Contractors, Sub-Contractors and Vendors of the service provider execute assurances that said Contractors, Sub-Contractors and Vendors are in compliance with Section 504.

The Contractor must enter into an agreement with each Sub-Contractor or Vendor under which there is the provision to furnish to the contractor, DHHS or RIDOH on request full and complete information related to Section 504 compliance.

The contractor must submit, within thirty-five (35) days of the date of a request by DHHS or RIDOH, full and complete information on Section 504 compliance by the Contractor and/or any Sub-Contractor or Vendor of the contractor.

It is the responsibility of each Contractor to acquaint itself with all of the provisions of the Section 504 regulations. A copy of the regulations, together with an August 14, 1978 Policy Interpretation of General Interest to Providers of Health, Welfare, or Other Social Services or Benefits, is available upon request from the Community Relations Liaison Officer, **RI Department of Health, 3 Capitol Hill Providence, RI 02908-5097 Tel: (401) 222-5960.**

Contractors should pay particular attention to subparts A, B, C, and F of the regulations which pertain to the following:



**SUBPART A - GENERAL PROVISIONS**

**SECTION:**

- 84.1 Purpose
- 84.2 Application
- 84.3 Definitions
- 84.4 Discrimination Prohibited
- 84.5 Assurance Required
- 84.6 Remedial Action, Voluntary Action, and Self-Evaluation
- 84.7 Designation of Responsible Employee and Adoption of Grievance Procedures
- 84.8 Notice
- 84.9 Administrative Requirements for Small Recipients
- 84.10 Effect of State or Local Law or Other Requirements and Effect of Employment Opportunities

**SUBPART B - EMPLOYMENT PRACTICES**

**SECTION:**

- 84.11 Discrimination Prohibited
- 84.12 Reasonable Accommodation
- 84.13 Employment Criteria
- 84.14 Pre-employment Inquiries
- 84.15 - 84.20 (Reserved)

**SUBPART C - ACCESSIBILITY**

**SECTION:**

- 84.21 Discrimination Prohibited
- 84.22 Existing Facilities
- 84.23 New Construction
- 84.24 - 84.30 (Reserved)

**SUBPART F - HEALTH, WELFARE, AND SOCIAL SERVICES**

**SECTION:**

- 84.51 Application of This Subpart
- 84.52 Health, Welfare, and Other Social Services
- 84.53 Drug and Alcohol Addicts
- 84.54 Education and Institutionalized Persons
- 84.55 Procedures Relating To Health Care for Handicapped Infants
- 84.56 – 84.60 (Reserved)

## ADDENDUM VII

### DRUG-FREE WORKPLACE POLICY

Drug use and abuse at the workplace or while on duty are subjects of immediate concern in our society. These problems are extremely complex and ones for which there are no easy solutions. From a safety perspective, the users of drugs may impair the well-being of all employees, the public at large, and result in damage to property. Therefore, it is the policy of the state that the unlawful manufacture, distribution, dispensation, possession, or use of a controlled substance is prohibited in the workplace. Any employee(s) violating this policy will be subject to discipline up to and including termination. An employee may also be discharged or otherwise disciplined for a conviction involving illicit drug use, regardless of whether the employee's conduct was detected within employment hours or whether his/her actions were connected in any way with his or her employment. The specifics of this policy are as follows:

1. Any unauthorized employee who gives or in any way transfers a controlled substance to another person or sells or manufactures a controlled substance while on duty, regardless of whether the employee is on or off the premises of the employer will be subject to discipline up to and including termination.
2. The term "controlled substance" means any drugs listed in 21 USC, Section 812 and other Federal regulations. Generally, all illegal drugs and substances are included, such as marijuana, heroin, morphine, cocaine, codeine or opium additives, LSD, DMT, STP, amphetamines, methamphetamines, and barbiturates.
3. Each employee is required by law to inform the agency within five (5) days after he/she is convicted for violation of any Federal or State criminal drug statute. A conviction means a finding of guilt (including a plea of nolo contendere) or the imposition of a sentence by a judge or jury in any Federal or State Court.
4. The employer (the hiring authority) will be responsible for reporting conviction(s) to the appropriate Federal granting source within ten (10) days after receiving notice from the employee or otherwise receives actual notice of such conviction(s). All conviction(s) must be reported in writing to the Office of Personnel Administration (OPA) within the same time frame.
5. If an employee is convicted of violating any criminal drug statute while on duty, he/ she will be subject to discipline up to and including termination. Conviction(s) while off duty may result in discipline or discharge.
6. The state encourages any employee with a drug abuse problem to seek assistance from the Rhode Island Employee Assistance Program (RIEAP). Your Personnel Officer has more information on RIEAP.
7. The law requires all employees to abide by this policy.

ADDENDUM VIII

**DRUG-FREE WORKPLACE POLICY  
CONTRACTOR CERTIFICATE OF COMPLIANCE**

I, \_\_\_\_\_, \_\_\_\_\_  
(Name) (Title)

**Name of Agency**, a contractor doing business with the state of Rhode Island hereby acknowledge that I have received a copy of the state's policy regarding the maintenance of a **Drug-Free Workplace**. I have been informed that the unlawful manufacture, distribution, dispensation, possession, or use of a controlled substance (to include but not limited to such drugs as marijuana, heroin, cocaine, PCP, and crack, and may also include legal drugs which may be prescribed by a licensed physician if they are abused), is prohibited on the State's premises or while conducting State business. I acknowledge that my employees must report for work in a fit condition to perform their duties.

As a condition for contracting with the state, as a result of the Federal Omnibus Drug Act, I will require my employees to abide by the state's policy. Further, I recognize that any violation of this policy may result in termination of the contract.

Signature: \_\_\_\_\_

Title: \_\_\_\_\_

Date: \_\_\_\_\_



**ADDENDUM X**

**CERTIFICATION REGARDING ENVIRONMENTAL TOBACCO SMOKE**

Public Law 103-227, Part c - Environmental Tobacco Smoke (20 U.S.C.A. § 6081-6084), also known as the Pro-Children Act of 1994 (**Act**), requires that smoking not be permitted in any portion of any indoor facility owned or leased or contracted for by an entity and used routinely or regularly for the provision of health, day care, education, or library services to children under the age of 18, if the services are funded by Federal programs either directly or through state or local governments, by Federal grant, contract, loan, or loan guarantee. The law does not apply to children's services provided in private residences, facilities funded solely by Medicare or Medicaid funds, and portions of facilities used for inpatient drug or alcohol treatment.

Any failure to comply with a prohibition in this section shall be a violation of this section and any person subject to such prohibition who commits such violation may be liable to the United States for a civil penalty in an amount not to exceed \$1,000 for each violation, or may be subject to an administrative compliance order, or both, as determined by the Secretary. Each day a violation continues shall constitute a separate violation. In the case of any civil penalty under this section, the total amount shall not exceed the amount of Federal funds received by such person for the fiscal year in which the continuing violations occurred.

By signing and submitting this application the applicant/contractor certifies that it will comply with the requirements of the Act. The applicant/contractor further agrees that it will require the language of this certification be included in any sub-awards which contain provisions for children's services and that all sub-contractors shall certify accordingly.

Signature: \_\_\_\_\_

Title: \_\_\_\_\_

Date: \_\_\_\_\_

## ADDENDUM XI

### INSTRUCTIONS FOR CERTIFICATION REGARDING DEBARMENT, SUSPENSION, AND OTHER RESPONSIBILITY MATTERS

#### PRIMARY COVERED TRANSACTIONS

By signing and submitting this proposal, the prospective primary participant is providing the certification set out below.

1. The inability of a person to provide the certification required below will not necessarily result in denial of participation in this covered transaction. If necessary, the prospective participant shall submit an explanation of why it cannot provide the certification. The certification or explanation will be considered in connection with RIDOH's determination whether to enter into this transaction. However, failure of the prospective primary participant to furnish a certification or explanation shall disqualify such person from participation in this transaction.
2. The certification in this clause is a material representation of fact upon which reliance was placed when RIDOH determined that the prospective primary participant knowingly rendered an erroneous certification, in addition to other remedies available to RIDOH. RIDOH may terminate this transaction for cause or default.
3. The prospective primary participant shall provide immediate written notice to RIDOH if at any time the prospective primary participant learns that its certification was erroneous when submitted or has become erroneous by reason of changed circumstances.
4. The terms "covered transaction," "debarred," "suspended," "ineligible," "lower tier covered transaction," "participant," "person," "primary covered transaction," "principal," "proposal," and "voluntarily excluded," as used in this clause, have the meanings set out in the definitions and coverage sections of the rules implementing Executive Order 12549.
5. The prospective primary participant agrees by submitting this proposal that, should the proposed covered transaction be entered into, it shall not knowingly enter into any lower tier covered transaction with a person who is debarred, suspended, declared ineligible, or voluntarily excluded from participation in this covered transaction, unless authorized by RIDOH.
6. The prospective primary participant further agrees by submitting this proposal that it will include the clause titled certification regarding debarment, suspension, ineligibility and voluntary exclusion - lower tier covered transactions, provided by RIDOH, without modification, in all lower tier covered transactions and in all solicitations for lower tier covered transactions.
7. A participant in a covered transaction may rely upon a certification of a prospective participant in a lower tier covered transaction that is not debarred, suspended, ineligible, or voluntarily excluded from the covered transaction, unless it knows that the certification is erroneous. A participant may decide the method and frequency by which it determines the eligibility of its principals. Each participant may, but is not required to, check the non-procurement list (of excluded parties).
8. Nothing contained in the foregoing shall be construed to require establishment of a system of records in order to render in good faith the certification required by this clause. The knowledge and information of a participant is not required to exceed that which is normally possessed by a prudent person in the ordinary course of business dealings.
9. Except for transactions authorized under Paragraph 6 of these instructions, if a participant in a covered transaction knowingly enters into a lower tier covered transaction with a person who is suspended, debarred, ineligible, or voluntarily excluded from participation in this transaction, in addition to other remedies available to the Federal Government, RIDOH may terminate this transaction for cause of default.

**ADDENDUM XII**

**CERTIFICATION REGARDING DEBARMENT, SUSPENSION,  
AND OTHER RESPONSIBILITY MATTERS – PRIMARY COVERED TRANSACTIONS**

The contractor, as the primary participant, certifies to the best of the contractor’s knowledge and belief, that the contractor and its principals:

1. Are not presently debarred, suspended, proposed for debarment, declared ineligible, or voluntarily excluded from covered transactions by any Federal department or agency;
2. Have not within a three (3) year period preceding this proposal been convicted of or had a civil judgment rendered against them for commission of fraud or a criminal offense in connection with obtaining, attempting to obtain, or performing a public (Federal, State or local) transaction or contract under public transaction; violation of federal or state antitrust statutes or commission of embezzlement, theft, forgery, bribery, falsification or destruction of records, making false statements, or receiving stolen property;
3. Are not presently indicated or otherwise criminally or civilly charged by a governmental entity (federal, State or local) with commission of any of the offenses enumerated in paragraph 2 of this certification; and
4. Have not within a three (3) year period preceding this application/proposal had one or more public transactions (Federal, State or local) terminated for cause or default.

Where the prospective primary participant is unable to certify to any of the statement in this certification, such prospective participant shall attach an explanation to this proposal.

Signature: \_\_\_\_\_

Title: \_\_\_\_\_

Date: \_\_\_\_\_

## ADDENDUM XIII

### LIQUIDATED DAMAGES

The prospective primary participant contractor agrees that time is of the essence in the performance of certain designated portions of this contract. RIDOH and the contractor agree that in the event of a failure to meet the milestones and project deliverable dates or any standard of performance within the time set forth in RIDOH's bid proposal and the contractor's proposal response (Addendum XVI), damage shall be sustained by RIDOH and that it may be impractical and extremely difficult to ascertain and determine the actual damages which RIDOH will sustain by reason of such failure. It is therefore agreed that RIDOH, at its sole option, may require the contractor to pay liquidated damages for such failures with the following provisions:

1. Where the failure is the sole and exclusive fault of RIDOH, no liquidated damages shall be imposed. To the extent that each party is responsible for the failure, liquidated damages shall be reduced by the apportioned share of such responsibility.
2. For any failure by the contractor to meet any performance standard, milestone or project deliverable, RIDOH may require the contractor to pay liquidated damages in the amount(s) and as set forth in the state's general conditions of purchase as described particularly in the LOI, RFP, RFQ, or scope of work, however, any liquidated damages assessed by RIDOH shall not exceed **10%** of the total amount of any such month's invoice in which the liquidated damages are assessed and shall not in the aggregate, over the life of the agreement, exceed the total contract value.

Written notification of failure to meet a performance requirement shall be given by RIDOH's project officer to the contractor's project officer. The contractor shall have a reasonable period designated by RIDOH from the date of receipt of written notification. If the failure is not materially resolved within this period, liquidated damages may be imposed retroactively to the date of expected delivery.

In the event that liquidated damages have been imposed and retained by RIDOH, any such damages shall be refunded, provided that the entire system takeover has been accomplished and approved by RIDOH according to the original schedule detailed in the contractor's proposal response included in this contract (Addendum XVI) as modified by mutually agreed upon change orders.

To the extent liquidated damages have been assessed, such damages shall be the sole monetary remedy available to RIDOH for such failure. This does not preclude the state from taking other legal action.



## **ADDENDUM XIV**

### **EQUAL EMPLOYMENT OPPORTUNITY**

During the performance of this agreement, the contractor agrees as follows:

1. The Contractor shall not discriminate against any employee or applicant for employment relating to this agreement because of race, color, religious creed, sex, national origin, ancestry, age, physical or mental disability, unless related to a bona fide occupational qualification. The Contractor shall take affirmative action to ensure that applicants are employed and employees are treated equally during employment, without regard to their race, color, religion, sex, age, national origin, or physical or mental disability.

Such action shall include but not be limited to the following: employment, upgrading, demotions, or transfers; recruitment or recruitment advertising; layoffs or terminations; rates of pay or other forms of compensation; and selection for training including apprenticeship. The Contractor agrees to post in conspicuous places available to employees and applicants for employment notices setting forth the provisions of this nondiscrimination clause.

2. The Contractor shall, in all solicitations or advertising for employees placed by or on behalf of the contractor relating to this agreement, state that all qualified applicants shall receive consideration for employment without regard to race, color, religious creed, sex, national origin, ancestry, age, physical or mental disability.
3. The Contractor shall inform the contracting RIDOH's equal employment opportunity coordinator of any discrimination complaints brought to an external regulatory body (RI Ethics Commission, RI Department of Administration, US DHHS Office of Civil Rights) against their agency by any individual as well as any lawsuit regarding alleged discriminatory practice.
4. The Contractor shall comply with all aspects of the Americans with Disabilities Act (ADA) in employment and in the provision of service to include accessibility and reasonable accommodations for employees and clients.
5. Contractors and subcontractors with agreements in excess of \$50,000 shall also pursue in good faith affirmative action programs.
6. The Contractor shall cause the foregoing provisions to be inserted in any subcontract for any work covered by this agreement so that such provisions shall be binding upon each subcontractor, provided that the foregoing provisions shall not apply to contracts or subcontracts for standard commercial supplies or raw materials.

**ADDENDUM XV**

**BYRD ANTI-LOBBYING AMENDMENT**

No Federal or State appropriated funds shall be expended by the contractor for influencing or attempting to influence an officer or employee of any agency, a member of congress or State Legislature, an officer or employee of congress or state legislature, or an employee of a member of congress or state legislature in connection with any of the following covered actions: the awarding of any agreement; the making of any grant; the entering into of any cooperative agreement; and the extension, continuation, renewal, amendment, or modification of any agreement, grant, or cooperative agreement. Signing this agreement fulfills the requirement that contractors receiving over \$100,000 in Federal or State funds file with RIDOH on this provision.

If any Non-Federal or State Funds have been or will be paid to any person in connection with any of the covered actions in this provision, the Contractor shall complete and submit a "Disclosure of Lobbying Activities" form.

The Contractor must certify compliance with all terms of the Byrd Anti-Lobbying Amendment (31 U.S.C 1352) as published in the Federal Register May 27, 2003, Volume 68, Number 101.

The Contractor hereby certifies that it will comply with Byrd Anti-Lobbying Amendment provisions as defined in 45 CFR Part 93 and as amended from time to time.

Signature: \_\_\_\_\_

Title: \_\_\_\_\_

Date: \_\_\_\_\_

**ADDENDUM XVI**

**BID PROPOSAL**

To access a copy of RFP # XXXXX, please go to:

<http://www.purchasing.ri.gov/bidding/Bidlisting.aspx> under solicitation number, insert the above RFP Number.

**OR:**

None

**ADDENDUM XVII**  
**CORE STAFF POSITIONS**

**(Add Staff/positions listed in budget)**

## ADDENDUM XVIII

### BUSINESS ASSOCIATE AGREEMENT

Except as otherwise provided in this Business Associate Agreement Addendum, **Name of Agency**, (hereinafter referred to as "Business Associate"), may use, access or disclose Protected Health Information to perform functions, activities or services for or on behalf of the State of Rhode Island, Department of Health (hereinafter referred to as the "Covered Entity"), as specified herein and the attached Agreement between the Business Associate and the Covered Entity (hereinafter referred to as "the Agreement"), which this addendum supplements and is made part of, provided such use, access, or disclosure does not violate the Health Insurance Portability and Accountability Act (HIPAA), 42 USC 1320d et seq., and its implementing regulations including, but not limited to, 45 CFR, parts 160, 162 and 164, hereinafter referred to as the Privacy and Security Rules and patient confidentiality regulations, and the requirements of the Health Information Technology for Economic and Clinical Health Act, as incorporated in the American Recovery and Reinvestment Act of 2009, Public Law 111-5 (HITECH Act) and any regulations adopted or to be adopted pursuant to the HITECH Act that relate to the obligations of business associates, Rhode Island Mental Health Law, R.I. General Laws Chapter 40.1-5-26, and Confidentiality of Health Care Communications and Information Act, R.I. General Laws Chapter 5-37.3-1 et seq. Business Associate recognizes and agrees it is obligated by law to meet the applicable provisions of the HITECH Act.

#### 1. Definitions

##### A. Generally:

- (1) Terms used, but not otherwise defined, in this Agreement shall have the same meaning as those terms in 45 C.F.R. §§ 160.103, 164.103, and 164.304, 164.501 and 164.502.
- (2) The following terms used in this Agreement shall have the same meaning as those terms in the HIPAA, the Privacy and Security Rules and the HITECH Act: Breach, Data Aggregation, Designated Record Set, Disclosure, Health Care Operations, Individual, Minimum Necessary, Notice of Privacy Practices, Protected Health Information, Required By Law, Secretary, Security Incident, Subcontractor, Unsecured Protected Health Information, and Use.

##### B. Specific:

- (1) "Addendum" means this Business Associate Agreement Addendum.
  - (2) "Agreement" means the contractual Agreement by and between the State of Rhode Island, Department of Health and Business Associate, awarded pursuant to State of Rhode Island's Purchasing Law (Chapter 37-2 of the Rhode Island General Laws) and Rhode Island Department of Administration, Division of Purchases, Purchasing Rules, Regulations, and General Conditions of Purchasing.
- A. "Business Associate" generally has the same meaning as the term "business associate" at 45 CFR 160.103, and in reference to the party to this agreement, shall mean **Name of Agency**.
  - B. "Client/Patient" means Covered Entity funded person who is a recipient and/or the client or patient of the Business Associate.
  - C. "Covered Entity" generally has the same meaning as the term "covered entity" at 45 CFR 160.103, and in reference to the party to this agreement, shall mean Department of Health.
  - D. "Electronic Health Record" means an electronic record of health-related information on an individual that is created, gathered, managed or consulted by authorized health care clinicians and staff.
  - E. "Electronic Protected Health Information" or "Electronic PHI" means PHI that is transmitted by or maintained in electronic media as defined in the HIPA Security Regulations.
  - F. "HIPAA" means the Health Insurance Portability and Accountability Act of 1996, Public Law 104-191.
  - G. "HIPAA Privacy Rule" means the regulations promulgated under HIPAA by the United States Department of Health and Human Services to protect the privacy of Protected Health Information including, the Privacy, Security, Breach Notification, and Enforcement Rules at 45 CFR Part 160 and Part 164.
  - H. "HITECH Act" means the privacy, security and security Breach notification provisions applicable to Business Associate under Subtitle D of the Health Information Technology for Economic and Clinical Health Act, which is Title XII of the American Recovery and Reinvestment Act of 2009, Public Law 111-5, and any regulations promulgated thereunder and as amended from time to time.

- I. "Secured PHI" means PHI that was rendered unusable, unreadable or indecipherable to unauthorized individuals through the use of technologies or methodologies specified under or pursuant to Section 13402 (h)(2) of the HITECH Act under ARRA.
- J. "Security Incident" means any known successful or unsuccessful attempt by an authorized or unauthorized individual to inappropriately use, disclose, modify, access, or destroy any information.
- K. "Security Rule" means the Standards for the security of Electronic Protected Health Information found at 45 CFR Parts 160 and 162, and Part 164, Subparts A and C. The application of Security provisions Sections 164.308, 164.310, 164.312, and 164.316 of title 45, Code of Federal Regulations shall apply to Business Associate of Covered Entity in the same manner that such sections apply to the Covered Entity.
- L. "Suspected breach" is a suspected acquisition, access, use or disclosure of protected health information ("PHI") in violation of HIPPA privacy rules, as referenced above, that compromises the security or privacy of PHI.
- M. "Unsecured PHI" means PHI that is not secured, as defined in this section, through the use of a technology or methodology specified by the Secretary of the U.S. Department of Health and Human Services.

## 2. Obligations and Activities of Business Associate

- A. Business Associate agrees to not use or further disclose PHI other than as permitted or required by this Agreement or as required by Law, provided such use or disclosure would also be permissible by law by Covered Entity.
- B. Business Associate agrees to use appropriate safeguards to prevent use or disclosure of the PHI other than as provided for by this Agreement. Business Associate agrees to implement Administrative Safeguards, Physical Safeguards and Technical Safeguards ("Safeguards") that reasonably and appropriately protect the confidentiality, integrity and availability of PHI as required by the "Security Rule."
- C. Business Associate agrees to mitigate, to the extent practicable, any harmful effect that is known to Business Associate of a use or disclosure of PHI by Business Associate in violation of the requirements of this Agreement.
- D. Business Associate agrees to report to Covered Entity any use or disclosure of the PHI not provided for by this Agreement, including breaches of unsecured PHI as required by 45 C.F.R. § 164.410, and any Security Incident of which it becomes aware, within five (5) days of the incident.
- E. Business Associate agrees to ensure that any agent, including a subcontractor or vendor, to whom it provides PHI received from, or created or received by Business Associate on behalf of Covered Entity agrees to the same restrictions and conditions that apply through this Agreement to Business Associate with respect to such information through a contractual arrangement that complies with 45 C.F.R. § 164.314.
- F. Business Associate agrees to provide paper or electronic access, at the request of Covered Entity and in the time and manner designated by Covered Entity, to PHI in a Designated Record Set to Covered Entity or, as directed by Covered Entity, to an Individual in order to meet the requirements under 45 C.F.R. § 164.524. If the Individual requests an electronic copy of the information, Business Associate must provide Covered Entity with the information requested in the electronic form and format requested by the Individual and/or Covered Entity if it is readily producible in such form and format; or, if not, in a readable electronic form and format as requested by Covered Entity.
- G. Business Associate agrees to make any amendment(s) to PHI in a Designated Record Set that Covered Entity directs or agrees to pursuant to 45 C.F.R. § 164.526 at the request of Covered Entity or an Individual, and in the time and manner designated by Covered Entity. If Business Associate receives a request for amendment to PHI directly from an Individual, Business Associate shall notify Covered Entity upon receipt of such request.
- H. Business Associate agrees to make its internal practices, books, and records relating to the use and disclosure of PHI received from, created or received by Business Associate on behalf of Covered Entity available to Covered Entity, or at the request of Covered Entity to the Secretary, in a time and manner designated by Covered Entity or the Secretary, for the purposes of the Secretary determining compliance with the Privacy Rule and Security Rule.
- I. Business Associate agrees to document such disclosures of PHI and information related to such disclosures as would be required for Covered Entity to respond to a request by an Individual for an accounting of disclosures of PHI in accordance with 45 C.F.R. § 164.528.
- J. Business Associate agrees to provide to Covered Entity or an Individual, in a time and manner designated by Covered Entity, information collected in accordance with this Agreement, to permit Covered Entity to respond to a request by an individual for an accounting of disclosures for PHI in accordance with 45 C.F.R. 164.528.
- K. If Business Associate accesses, maintains, retains, modifies, records, stores, destroys, or otherwise holds, uses, or discloses Unsecured Protected Health Information (as defined in 45 C.F.R. § 164.402) for Covered Entity, it shall, following the discovery of a breach of such information, notify Covered Entity of such breach within a period of five (5) days after discovery of the breach. Such notice shall include: a) the identification of each individual whose Unsecured Protected Health Information has been, or is reasonably believed by Business Associate to have been accessed, acquired or disclosed during such breach; b) a brief description of what happened, including the date of the breach and discovery of the breach; c) a description of the type of Unsecured PHI that was involved in the breach; d)

a description of the investigation into the breach, mitigation of harm to the individuals and protection against further breaches; e) the results of any and all investigation performed by Business Associate related to the breach; and f) contact information of the most knowledgeable individual for Covered Entity to contact relating to the breach and its investigation into the breach.

- L. To the extent the Business Associate is carrying out an obligation of the Covered Entity's under the Privacy Rule, the Business Associate must comply with the requirements of the Privacy Rule that apply to the Covered Entity in the performance of such obligation.
- M. Business Associate agrees that it will not receive remuneration directly or indirectly in exchange for PHI without authorization unless an exception under 45 C.F.R. § 164.502(a)(5)(ii)(B)(2) applies.
- N. Business Associate agrees that it will not receive remuneration for certain communications that fall within the exceptions to the definition of Marketing under 45 C.F.R. § 164.501, unless permitted by 45 C.F.R. § 164.508(a)(3)(A)-(B).
- O. If applicable, Business Associate agrees that it will not use or disclose genetic information for underwriting purposes, as that term is defined in 45 C.F.R. § 164.502.
- P. Business Associate hereby agrees to comply with state laws and rules and regulations applicable to PHI and personal information of individuals' information it receives from Covered Entity during the term of the Agreement.
  - i. Business Associate agrees to: (a) implement and maintain appropriate physical, technical and administrative security measures for the protection of personal information as required by any state law and rules and regulations; including, but not limited to: (i) encrypting all transmitted records and files containing personal information that will travel across public networks, and encryption of all data containing personal information to be transmitted wirelessly; (ii) prohibiting the transfer of personal information to any portable device unless such transfer has been approved in advance; and (iii) encrypting any personal information to be transferred to a portable device; and (b) implement and maintain a Written Information Security Program as required by any state law as applicable.
  - ii. The safeguards set forth in this Agreement shall apply equally to PHI, confidential and "personal information." Personal information means an individual's first name and last name or first initial and last name in combination with any one or more of the following data elements that relate to such resident: (a) Social Security number; (b) driver's license number or state-issued identification card number; or (c) financial account number, or credit or debit card number, with or without any required security code, access code, personal identification number or password, that would permit access to a resident's financial account; provided, however, that "personal information" shall not include information that is lawfully obtained from publicly available information, or from federal, state or local government records lawfully made available to the general public.

### 3. Permitted Uses and Disclosures by Business Associate

- A. Except as otherwise limited to this Agreement, Business Associate may use or disclose PHI to perform functions, activities, or services for, or on behalf of, Covered Entity as specified in the Service Arrangement, provided that such use or disclosure would not violate the Privacy Rule if done by Covered Entity or the minimum necessary policies and procedures of Covered Entity required by 45 C.F.R. § 164.514(d).
- B. Except as otherwise limited in this Agreement, Business Associate may use PHI for the proper management and administration of the Business Associate or to carry out the legal responsibilities of the Business Associate.
- C. Except as otherwise limited in this Agreement, Business Associate may disclose PHI for the proper management and administration of the Business Associate, provided that disclosures are Required By Law, or Business Associate obtains reasonable assurances from the person to whom the information is disclosed that it will remain confidential and used or further disclosed only as Required By Law or for the purpose for which it was disclosed to the person, and the person notifies the Business Associate of any instances of which it is aware in which the confidentiality of the information has been breached.
- D. Except as otherwise limited in this Agreement, Business Associate may use PHI to provide Data Aggregation services to Covered Entity as permitted by 45 C.F.R. § 164.504 (e)(2)(i)(B).
- E. Business Associate may use PHI to report violations of law to appropriate Federal and State authorities, consistent with 45 C.F.R. § 164.502(j)(1).

### 4. Obligations of Covered Entity

- A. Covered Entity shall notify Business Associate of any limitation(s) in its notice of privacy practices of Covered Entity in accordance with 45 C.F.R. § 164.520, to the extent that such limitation may affect Business Associate's use or disclosure of PHI.

- B. Covered Entity shall notify Business Associate of any changes in, or revocation of, permission by an Individual to use or disclose PHI to the extent that such changes may affect Business Associate's use or disclosure of PHI.
- C. Covered Entity shall notify Business Associate of any restriction to the use or disclosure of PHI that Covered Entity has agreed to in accordance with 45 C.F.R. §164.522, to the extent that such restriction may affect Business Associate's use or disclosure of PHI.

5. Permissible Requests by Covered Entity

Covered Entity shall not request Business Associate to use or disclose PHI in any manner that would not be permissible under the Privacy Rule if done by Covered Entity, provided that, to the extent permitted by the Service Arrangement, Business Associate may use or disclose PHI for Business Associate's Data Aggregation activities or proper management and administrative activities.

6. Term and Termination

- A. The term of this Agreement shall begin as of the effective date of the Service Arrangement and shall terminate when all of the PHI provided by Covered Entity to Business Associate, or created or received by Business Associate on behalf of Covered Entity, is destroyed or returned to Covered Entity, or, if it is infeasible to return or destroy PHI, protections are extended to such information, in accordance with the termination provisions of this Section.
- B. Upon Covered Entity's knowledge of a material breach by Business Associate, Covered Entity shall either:
  - i. Provide an opportunity for Business Associate to cure the breach or end the violation and terminate this Agreement and the Service Arrangement if Business Associate does not cure the breach or end the violation within the time specified by Covered Entity.
  - ii. Immediately terminate this Agreement and the Service arrangement if Business Associate has breached a material term of this Agreement and cure is not possible.
- C. Except as provided in paragraph (d) of this Section, upon any termination or expiration of this Agreement, Business Associate shall return or destroy all PHI received from Covered Entity, or created or received by Business Associate on behalf of Covered Entity. This provision shall apply to PHI that is in the possession of subcontractors or agents of Business Associate. Business Associate shall retain no copies of the PHI. Business Associate shall ensure that its subcontractors or vendors return or destroy any of Covered Entity's PHI received from Business Associate.
- D. In the event that Business Associate determines that returning or destroying the PHI is infeasible, Business Associate shall provide to Covered Entity notification of the conditions that make return or destruction infeasible. Upon Covered Entity's written agreement that return or destruction of PHI is infeasible, Business Associate shall extend the protections of this Agreement to such PHI and limit further uses and disclosures of such PHI to those purposes that make the return or destruction infeasible, for so long as Business Associate maintains such PHI.

7. Miscellaneous

- A. A reference in this Agreement to a section in the Privacy Rule or Security Rule means the section as in effect or as amended.
- B. The Parties agree to take such action as is necessary to amend this Agreement from time to time as is necessary for Covered Entity to comply with the requirements of HIPAA, the Privacy and Security Rules and HITECH.
- C. The respective rights and obligations of Business Associate under Section 6 (c) and (d) of this Agreement shall survive the termination of this Agreement.
- D. Any ambiguity in this Agreement shall be resolved to permit Covered Entity to comply with HIPAA and HITECH.
- E. Business Associate is solely responsible for all decisions made by Business Associate regarding the safeguarding of PHI.
- F. Nothing express or implied in this Agreement is intended to confer, nor shall anything herein confer upon any person other than Covered Entity, Business Associate and their respective successors and assigns, any rights, remedies, obligations or liabilities whatsoever.
- G. Modification of the terms of this Agreement shall not be effective or binding upon the parties unless and until such modification is committed to writing and executed by the parties hereto.
- H. This Agreement shall be binding upon the parties hereto, and their respective legal representatives, trustees, receivers, successors and permitted assigns.



- I. Should any provision of this Agreement be found unenforceable, it shall be deemed severable and the balance of the Agreement shall continue in full force and effect as if the unenforceable provision had never been made a part hereof.
- J. This Agreement and the rights and obligations of the parties hereunder shall in all respects be governed by, and construed in accordance with, the laws of the State of Rhode Island, including all matters of construction, validity and performance.
- K. All notices and communications required or permitted to be given hereunder shall be sent by certified or regular mail, addressed to the other part as its respective address as shown on the signature page, or at such other address as such party shall from time to time designate in writing to the other party, and shall be effective from the date of mailing.
- L. This Agreement, including such portions as are incorporated by reference herein, constitutes the entire agreement by, between and among the parties, and such parties acknowledge by their signature hereto that they do not rely upon any representations or undertakings by any person or party, past or future, not expressly set forth in writing herein.
- M. Business Associate shall maintain or cause to be maintained sufficient insurance coverage as shall be necessary to insure Business Associate and its employees, agents, representatives or subcontractors against any and all claims or claims for damages arising under this Business Associate Agreement and such insurance coverage shall apply to all services provided by Business Associate or its agents or subcontractors pursuant to this Business Associate Agreement. Business Associate shall indemnify, hold harmless and defend Covered Entity from and against any and all claims, losses, liabilities, costs and other expenses (including but not limited to, reasonable attorneys' fees and costs, administrative penalties and fines, costs expended to notify individuals and/or to prevent or remedy possible identity theft, financial harm, reputational harm, or any other claims of harm related to a breach) incurred as a result of, or arising directly or indirectly out of or in connection with any acts or omissions of Business Associate, its employees, agents, representatives or subcontractors, under this Business Associate Agreement, including, but not limited to, negligent or intentional acts or omissions. This provision shall survive termination of this Agreement.

8. Acknowledgment

The undersigned affirms that he/she is a duly authorized representative of the Business Associate for which he/she is signing and has the authority to execute this Addendum on behalf of the Business Associate.

Acknowledged and agreed to by:

Rhode Island Department of Health

Name of Agency

Nicole Alexander-Scott, MD, MPH  
Director of Health

Name  
Title

Date: \_\_\_\_\_

Date: \_\_\_\_\_

## KIDSNET Technical Description

KIDSNET, is a complex database with an operating environment consisting of a Linux server operating Oracle 10g and 10gAS, connected to a SAN and running Oracle Reports, Forms, and Oracle Application Express within the 10gAS Application Server. A variety of automated import and other batch processes also exist on the server, in Perl, shell, and SQL scripts managed through an Apache-based CGI application and through Linux crontab. A Java-based web application, on a separate Linux server, also accesses the 10g database. An immunization algorithm web service and associated batch processes run on a Windows 2000 server in support of the KIDSNET applications. Processes that synchronize information between the State Supplied Vaccine (SSV) registration system and the CDC VACMAN software also run on this server. Remote access to the servers for developers and administrators is available via a Juniper Networks SSL VPN service operated by the RI Information Technology Division.

# **Helpful WIC Table Groupings**

CREATED BY: Maggie O'Malley  
CREATED: 3/2012  
UPDATED: 07/17/2014

# Appointments Tables

**PLEASE NOTE:** Although there is a table called **APPOINTMENTSSCHEDULED**, there is no data in this table and is not currently in use

Data Information

**APPOINTMENT**  
Parents are MEMBER and AGENCY

<b>APPOINTMENTID(PK)</b>	NUMBER (10) Not Null
AGENCYID	VARCHAR2 (3 Byte) Not Null
SERVICESTEID	VARCHAR2 (3 Byte)
APPOINTMENTDATE	DATE
APPOINTMENTTIME	VARCHAR2 (4 Byte) Not Null
APPOINTMENTTYPEID	NUMBER (10)
RESOURCEID	NUMBER (10)
<b>STATEWICID</b>	VARCHAR2 (8 Byte)
HOUSEHOLDID	VARCHAR2 (8 Byte)
DURATION	NUMBER (3)
QUEUEDNOTICE	CHAR (1 Byte)
APPOINTMENTKEPT	CHAR (1 Byte)
MISSEDNOTICEPRODUCED	CHAR (1 Byte)
RESOURCECOLUMN	NUMBER (2) Not Null
CONFIRMED	VARCHAR2 (1 Byte)
CREATEUSERID	VARCHAR2 (10 Byte)
CREATEDATE	DATE
CREATETIME	VARCHAR2 (8 Byte)
MODIFYUSERID	VARCHAR2 (10 Byte)
MODIFYDATE	DATE
MODIFYTIME	VARCHAR2 (8 Byte)

Data Information

**CLASSENROLLMENT**  
Parents are CLASSSSCHEDULE and MEMBER

<b>ENROLLMENTID(PK)</b>	NUMBER (10) Not Null
<b>CLASSSSCHEDULEID</b>	NUMBER (10) Not Null
<b>STATEWICID</b>	VARCHAR2 (8 Byte) Not Null
HOUSEHOLDID	VARCHAR2 (8 Byte)
QUEUEDNOTICE	CHAR (1 Byte)
ENROLLMENTKEPT	CHAR (1 Byte)
MISSEDNOTICEPRODUCED	CHAR (1 Byte)
CREATEUSERID	VARCHAR2 (10 Byte)
CREATEDATE	DATE
CREATETIME	VARCHAR2 (8 Byte)
MODIFYUSERID	VARCHAR2 (10 Byte)
MODIFYDATE	DATE
MODIFYTIME	VARCHAR2 (8 Byte)
CONFIRMED	CHAR (1 Byte)

Reference Information

**CLASSSSCHEDULE**  
Parents are SERVICESITE and APPOINTMENTRESOURCE

<b>CLASSSSCHEDULEID(PK)</b>	NUMBER (10) Not Null
AGENCYID	VARCHAR2 (3 Byte) Not Null
SERVICESTEID	VARCHAR2 (3 Byte) Not Null
CLASSTYPEID	NUMBER (10) Not Null
CLASSDATE	DATE
CLASSTIME	VARCHAR2 (4 Byte)
DURATION	NUMBER (3)
APPOINTMENTRESOURCEID	NUMBER (10)
LANGUAGE	VARCHAR2 (1 Byte)
SEATAVAILABLE	NUMBER (3)
SEATSFILLED	NUMBER (3)
CREATEUSERID	VARCHAR2 (10 Byte)
CREATEDATE	DATE
CREATETIME	VARCHAR2 (8 Byte)
MODIFYUSERID	VARCHAR2 (10 Byte)
MODIFYDATE	DATE
MODIFYTIME	VARCHAR2 (8 Byte)
RESOURCECOLUMN	NUMBER (2) Not Null

Reference Information

**APPOINTMENTRESOURCE**  
Parent is AGENCY

<b>APPOINTMENTRESOURCEID(PK)</b>	NUMBER (10) Not Null
AGENCYID	VARCHAR2 (3 Byte)
NAME	VARCHAR2 (50 Byte)
RESOURCELEVEL	VARCHAR2 (1 Byte)
APPOINTMENTSVIEWABLE	CHAR (1 Byte)
CREATEUSERID	VARCHAR2 (10 Byte)
CREATEDATE	DATE
CREATETIME	VARCHAR2 (8 Byte)
MODIFYUSERID	VARCHAR2 (10 Byte)
MODIFYDATE	DATE
MODIFYTIME	VARCHAR2 (8 Byte)
NODELETE	CHAR (1 Byte)

Reference Information

**CLASSTYPE**  
Parent is AGENCY

<b>CLASSTYPEID(PK)</b>	NUMBER (10) Not Null
AGENCYID	VARCHAR2 (3 Byte)
TOPIC	VARCHAR2 (50 Byte)
SHORTDESCRIPTION	VARCHAR2 (10 Byte)
CLASSLEVEL	VARCHAR2 (1 Byte)
CREATEUSERID	VARCHAR2 (10 Byte)
CREATEDATE	DATE
CREATETIME	VARCHAR2 (8 Byte)
MODIFYUSERID	VARCHAR2 (10 Byte)
MODIFYDATE	DATE
MODIFYTIME	VARCHAR2 (8 Byte)
NODELETE	CHAR (1 Byte)

Reference Information

**APPOINTMENTTYPE**  
Parent is AGENCY

<b>APPOINTMENTTYPEID(PK)</b>	NUMBER (10) Not Null
AGENCYID	VARCHAR2 (3 Byte)
DESCRIPTION	VARCHAR2 (50 Byte)
SHORTDESCRIPTION	VARCHAR2 (10 Byte)
CREATEUSERID	VARCHAR2 (10 Byte)
CREATEDATE	DATE
CREATETIME	VARCHAR2 (8 Byte)
MODIFYUSERID	VARCHAR2 (10 Byte)
MODIFYDATE	DATE
MODIFYTIME	VARCHAR2 (8 Byte)
NODELETE	CHAR (1 Byte)

Reference Information

**BUSINESSHOUR**  
Parent is BUSINESSDAY

<b>AGENCYID</b>	<b>VARCHAR2 (3)(PK)</b>
<b>SERVICESTEID</b>	<b>VARCHAR2 (3)(PK)</b>
<b>BUSINESSDATE</b>	<b>DATE (PK)</b>
<b>STARTTIME</b>	<b>VARCHAR2 (4)(PK)</b>
<b>ENDTIME</b>	<b>VARCHAR2 (4)</b>
CREATEUSERID	VARCHAR2 (10)
CREATEDATE	DATE
CREATETIME	VARCHAR2 (8)
MODIFYUSERID	VARCHAR2 (10)
MODIFYDATE	DATE
MODIFYTIME	VARCHAR2 (8)

Reference Information

**DEFAULTDURATION**  
Parent is SERVICESITE

<b>AGENCYID</b>	<b>VARCHAR2 (3)</b>
<b>SERVICESTEID</b>	<b>VARCHAR2 (3)</b>
<b>TYPEID</b>	<b>NUMBER (10)</b>
DEFAULTDURATION	NUMBER (3)
CREATEUSERID	VARCHAR2 (10)
CREATEDATE	DATE
CREATETIME	VARCHAR2 (8)
MODIFYUSERID	VARCHAR2 (10)
MODIFYDATE	DATE
MODIFYTIME	VARCHAR2 (8)

Reference Information

**BUSINESSDAY**  
Parent is SERVICESITE

<b>AGENCYID</b>	<b>VARCHAR2 (3)(PK)</b>
<b>SERVICESTEID</b>	<b>VARCHAR2 (3)(PK)</b>
<b>BUSINESSDATE</b>	<b>DATE (PK)</b>
SATELLITESERVERID	NUMBER (10)
NOTES	VARCHAR2 (4000)
CREATEUSERID	VARCHAR2 (10)
CREATEDATE	DATE
CREATETIME	VARCHAR2 (8)
MODIFYUSERID	VARCHAR2 (10)
MODIFYDATE	DATE
MODIFYTIME	VARCHAR2 (8)

Reference Information

**Holiday**  
Parent is AGENCY

<b>AGENCYID</b>	<b>VARCHAR2 (3)(PK)</b>
<b>HOLIDAYDATE</b>	<b>DATE (PK)</b>
DESCRIPTION	VARCHAR2 (50)
CREATEUSERID	VARCHAR2 (10)
CREATEDATE	DATE
CREATETIME	VARCHAR2 (8)
MODIFYUSERID	VARCHAR2 (10)
MODIFYDATE	DATE
MODIFYTIME	VARCHAR2 (8)
PREFERREDAPPOINTMENTTIME	VARCHAR2 (4)

Reference Information

**RESOURCESCHEDULE**  
Parents are SERVICESITE and APPOINTMENTRESOURCE

<b>AGENCYID</b>	<b>VARCHAR2 (3)(PK)</b>
<b>SERVICESTEID</b>	<b>VARCHAR2 (3)(PK)</b>
<b>APPOINTMENTRESOURCEID</b>	<b>NUMBER (10)(PK)</b>
<b>AVAILABILITYDATE</b>	<b>DATE (PK)</b>
<b>STARTTIME</b>	<b>VARCHAR2 (4)(PK)</b>
<b>ENDTIME</b>	<b>VARCHAR2 (4)</b>
CREATEUSERID	VARCHAR2 (10)
CREATEDATE	DATE
CREATETIME	VARCHAR2 (8)
MODIFYUSERID	VARCHAR2 (10)
MODIFYDATE	DATE
MODIFYTIME	VARCHAR2 (8)
AVAILABILITYCOLUMNS	NUMBER (2)

# Food Instrument and Member Info Tables

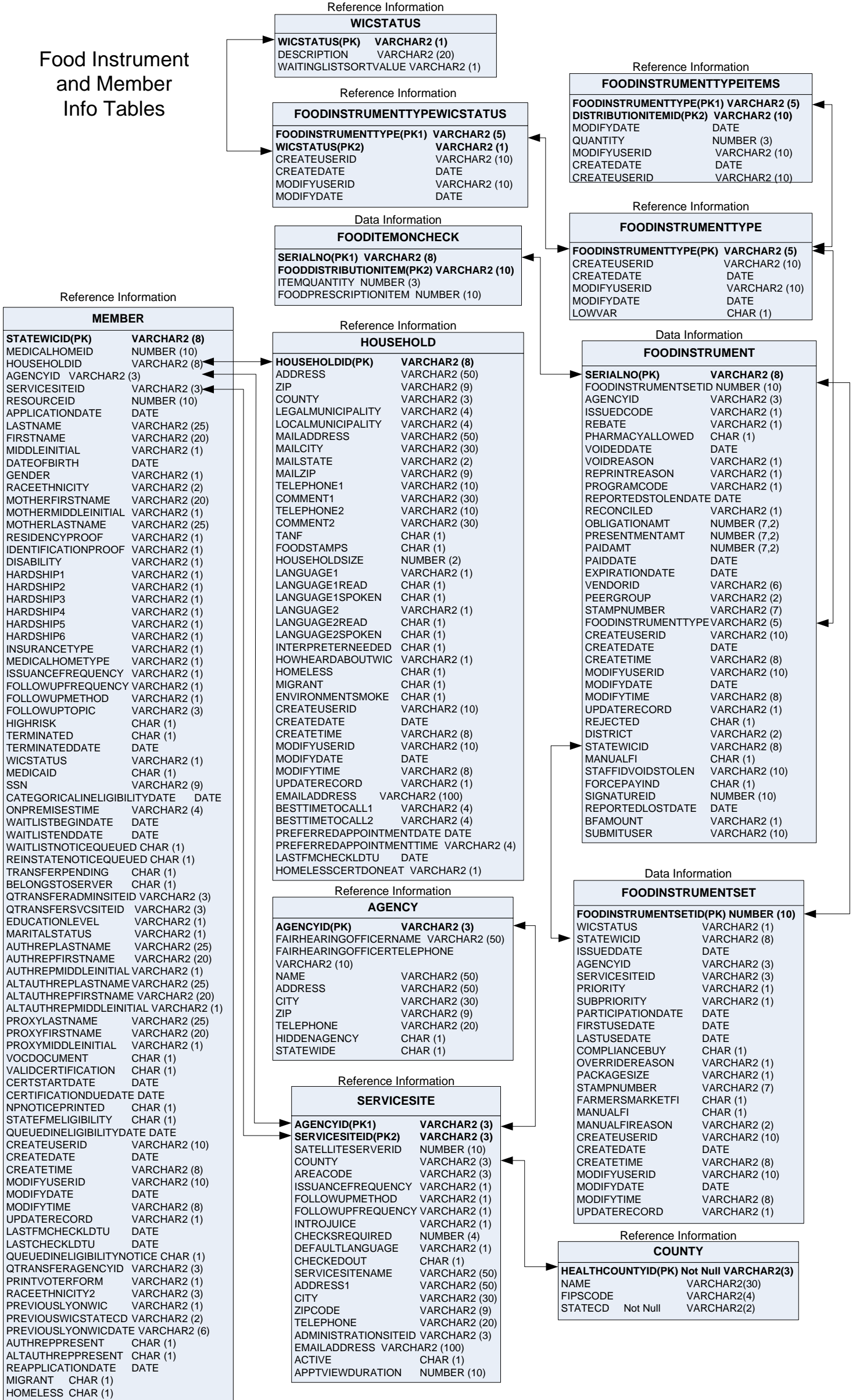

Base Food Category Codes

- A - FORMULA
- B - MILK AND CHEESE
- C - BEANS AND PEANUT BUTTER
- D - EGGS
- F - JUICE
- G - CEREAL
- I - INFANT CEREAL
- J - ENHANCED BREASTFEEDING
- K - INFANT JUICE
- L - FARMERS MARKET
- M - EXCLUSIVELY BREASTFEEDING
- N - WHOLE GRAINS
- O - CANNED FISH
- P - BABY FOOD MEATS
- Q - BABY FOOD FRUITS AND VEGETABLE
- R - FRUITS AND VEGETABLES
- S - FULLY BREASTFEEDING
- T - SPECIAL MILK AND CHEESE

# Prescription and Food tables

This is the "Override" table for the FoodRXItem table. If an equivalenceunits amount for a prescriptionID isn't in this table, then the equivalenceunits value from the FoodRXItem table is used

- Rough order of Utility tool updates into the food tables**
1. FOODDISTRIBUTIONITEM table
  2. PEERGROUPFOODITEM
  3. PEERGROUPFOODITEMHISTORY then VENDORPRICES
  4. FOODDISTRIBUTIONCATEGORY
  5. FOODRXITEM
  6. ITEMPURCHASESIZE
- 
- Food Items (including special milk)**
7. FOODLISTENTRY Then FOODLISTENTRYITEM OR
- Milk Cheese/Combo Items**
7. MILKFORMULATIONITEM
- 
8. PRESCRIPTIONITEMTRANSLATION

Reference Information

FOODDISTRIBUTIONCATEGORY	
BASEFOODCATEGORYID(PK1)	VARCHAR2 (1)
DISTRIBUTIONITEMID(PK2)	VARCHAR2 (10)
CREATE_USER_ID	VARCHAR2 (10)
CREATE_DATE	DATE
MODIFY_USER_ID	VARCHAR2 (10)
MODIFY_DATE	DATE

Reference Information

FOODDISTRIBUTIONITEM	
DISTRIBUTIONITEMID(PK)	VARCHAR2 (10)
DESCRIPTION	VARCHAR2 (60)
DESCRIPTION2	VARCHAR2 (60)
FOODPRODUCTID	NUMBER (10)
DESCRIPTION3	VARCHAR2 (60)
DESCRIPTION4	VARCHAR2 (60)

FORMULAPACKAGEQTY

BFAMOUNT(PK1)	CHAR (1 Byte)
AGECATEGORY(PK2)	CHAR (1 Byte)
FORMULAPACKAGEID(PK3)	NUMBER (10)
MAXIMUMUNITS	NUMBER (5,2)

FOODCATEGORYQTY

CATEGORYID	NUMBER (10)
WICSTATUS	CHAR (1 Byte)
AGECATEGORY	CHAR (1 Byte)
BFAMOUNT	CHAR (1 Byte)
MAXIMUMUNITS	NUMBER (6,2)

Reference Information

FOODCATEGORY	
CATEGORYID(PK)	NUMBER (10)
BASEFOODCATEGORYID	VARCHAR2 (1)
DESCRIPTION	VARCHAR2 (30)
WICSTATUS	VARCHAR2 (1)
MAXIMUMUNITS	NUMBER (6,2)

Reference Information

ITEMPURCHASESIZE	
PURCHASESIZEID(PK)	NUMBER (10)
PRESCRIPTIONITEMID	NUMBER (10)
QUANTITY	NUMBER (8,3)
DISTRIBUTIONITEMID	VARCHAR2 (10)
ROUNDUPFACTOR	NUMBER (3,2)
ADDQUANTITYFACTOR	NUMBER (3,2)
LINKAGETYPE	VARCHAR2 (1)
LINKEDDISTRIBUTIONITEMID	NUMBER (10)
CONVERSIONFACTOR	NUMBER (10)

FOODRXEQUUNITS

PRESCRIPTIONITEMID	NUMBER (10)
WICSTATUS	CHAR (1 Byte)
AGECATEGORY	CHAR (1 Byte)
BFAMOUNT	CHAR (1 Byte)
EQUIVALENCEUNITS	NUMBER (8,3)

Reference Information

FOODRXITEM	
PRESCRIPTIONITEMID(PK)	NUMBER (10)
CATEGORYID	NUMBER (10)
PACKAGEID	NUMBER (10)
DESCRIPTION	VARCHAR2 (60)
EQUIVALENCEUNITS	NUMBER (8,4)
DISTRIBUTIONRULE	VARCHAR2 (1)
CHECKNUMBER	VARCHAR2 (10)
MAXQUANTITYONCHECK	NUMBER (6,2)
FORMULATYPE	VARCHAR2 (1)
FORMULAFORMULATION	VARCHAR2 (1)
REBATECONTRACT	VARCHAR2 (1)
PRORATE	VARCHAR2 (1)
MAXIMUMUNITS	NUMBER (6,2)
BASEFOODCATEGORYID	VARCHAR2 (1)
REQUIREACCESSCODE	VARCHAR2 (1)

Reference Information

FOODLISTENTRYITEM	
LISTENTRYITEMID(PK1)	NUMBER (10)
BFAMOUNT(PK2)	CHAR (1 Byte)
LINKEDITEMID	NUMBER (10)
LISTENTRYID	NUMBER (10)
PRESCRIPTIONITEMID	NUMBER (10)
QUANTITY	NUMBER (10)
LINKAGETYPE	VARCHAR2 (1)

These tables are not directly related to the prescription tables, but they are a part of the inserts for new food items added to the database

- PEERGROUPFOODITEM
- PEERGROUPFOODITEMHISTORY
- VENDORPRICES

Reference Information

FOODLISTENTRY	
LISTENTRYID(PK)	NUMBER (10)
INTERNALDESCRIPTION	VARCHAR2 (30)
FOODSUBCATEGORYID	NUMBER (10)
WICSTATUS	VARCHAR2 (1)
CATEGORYID	NUMBER (10)
AGECATEGORYID	VARCHAR2 (2)

FOODSUBCATEGORY

FOODSUBCATEGORYID(PK)	NUMBER (10)
DESCRIPTION	VARCHAR2 (60)

This is a "Override" table for the foodcategoryqty table. If an maximumunits amount for a bfamount (from the foodlistentryitem), and agecategory (from the FoodRXItem) isn't in this table, then the next check is for the maximumunits value from the FoodCategoryQty table where the categoryid and WIC status (from the Foodcategory table), and agecategory (from the foodlistentry), and bfamount (from the foodlistentryitem)

This is a "Override" table for the foodcategory table. If an maximumunits amount for a bfamount (from the foodlistentryitem), and agecategory (from the foodlistentry), and formulapackageid (from the FoodRXItem) isn't in this table, then the maximumunits value from the FoodCategory table is used

DefaultFoodPackageItem

DEFAULTFOODPACKAGEID(PK)	NUMBER(10)
DEFAULTFOODPACKAGEITEMID(PK)	NUMBER(10)
PRESCRIPTIONITEMID	NUMBER(10)
QUANTITY	NUMBER(6,2)

DefaultFPItems\_RF335

WICSTATUS(PK)	VARCHAR2(1)
BFAMOUNT(PK)	VARCHAR2(1)
ODDEVENMONTH(PK)	VARCHAR2(1)
PRESCRIPTIONITEMID(PK)	NUMBER(10)
QUANTITY	NUMBER(6,2)
MILKFORMULATIONFLAG	VARCHAR2(1)
CHEESEFLAG	VARCHAR2(1)

PrescriptionItemTranslation

SOURCEWICSTATUS(PK)	VARCHAR2 (1)
SOURCEPRESCRIPTIONITEMID(PK)	NUMBER (10)
TARGETWICSTATUS	VARCHAR2 (1)
TARGETPRESCRIPTIONITEMID	NUMBER (10)

Data Information

FOODPRESCRIPTIONITEM	
STATEWICID(PK1)	VARCHAR2 (8 Byte)
PRESCRIPTIONDATE(PK2)	DATE
FOODPRESCRIPTIONITEM(PK3)	NUMBER (10)
ITEMQUANTITY	NUMBER (3)
SPECIALRXSTART	DATE
SPECIALRXEND	DATE

Data Information

FOODPRESCRIPTION	
STATEWICID(PK1)	VARCHAR2 (8)
PRESCRIPTIONDATE(PK2)	DATE
MILKPRODUCTSQUANTITY	NUMBER (2)
MILKFORMULATION	NUMBER (5)
CHEESEQUANTITY	NUMBER (1)
ENHBFITEMSADDED	CHAR (1)
WICSTATUS	VARCHAR2 (1)
CREATEUSERID	VARCHAR2 (10)
CREATEDATE	DATE
MODIFYUSERID	VARCHAR2 (10)
MODIFYDATE	DATE
UPDATERECORD	VARCHAR2 (1)
CREATETIME	VARCHAR2 (8)
MODIFYTIME	VARCHAR2 (8)
FOODPRESCRIPTIONTYPEID	NUMBER (10)

Reference Information

MILKFORMULATIONITEM	
MILKFORMULATIONITEMID(PK1)	NUMBER (10)
BFAMOUNT(PK2)	VARCHAR2 (1)
AGECATEGORYID(PK3)	CHAR (1)
WICSTATUS(PK4)	VARCHAR2 (1)
PRESCRIPTIONITEMID	NUMBER (10)
DESCRIPTION	VARCHAR2 (30)
MAXIMUMUNITS	NUMBER (5)
MAXCHEESEQUANTITY	NUMBER (5)
SORTVALUE	INTEGER

Nota Bene: Prescription table Milk food items will be found in the MilkFormulationItem table and all other prescription food items will be found in the FoodPrescriptionItem table

## Risk factor, Certcontact, and Caseloadcount tables

Reference Information – RF ID has one description, but multiple records because of BF amts, WICStatus, and Age Category.

Data Information – Multiple certs for each State WIC Id

Certcontact table	
<b>CERTIFICATIONID(PK) NOT NULL</b>	<b>NUMBER(10)</b>
PREGNANCYID	NUMBER(10)
STATEWICID	NOT NULL VARCHAR2(8)
CERTSTARTDATE	NOT NULL DATE
CERTEFFECTIVEDATE	DATE
CERTENDDATE	DATE
CERTTERMDATE	DATE
CERTTERMREASON	VARCHAR2(1)
VOCDOCUMENT	CHAR(1)
CERTINELIGIBLEDATE	DATE
CERTINELIGIBLEREASON	VARCHAR2(1)
CERTASSIGNEDPRIORITY	VARCHAR2(1)
CERTSERVICESITEID	VARCHAR2(3)
AGENCYID	VARCHAR2(3)
MANUALCERT	CHAR(1)
MANUALCERTREASON	VARCHAR2(2)
CERTWICSTATUS	VARCHAR2(1)
CREATEUSERID	VARCHAR2(10)
CREATEDATE	DATE
CREATETIME	VARCHAR2(8)
MODIFYUSERID	VARCHAR2(10)
MODIFYDATE	DATE
MODIFYTIME	VARCHAR2(8)
UPDATERECORD	VARCHAR2(1)
CERTASSIGNEDSUBPRIORITY	VARCHAR2(1)
CERTAGENCYID	VARCHAR2(3)
SERVICESITEID	VARCHAR2(3)
MANUALCHECKSISSUED	CHAR(1)
PHYSICALLYPRESENT	VARCHAR2(1)
CDCREPORTEDDT	DATE
INFORELEASESIGNED	VARCHAR2(1)
REAPPLICATIONNOTICEPRODUCED	VARCHAR2(1)
REASONNOTPHYSPRESENT	CHAR(1)
AUTHREPPRESENT	CHAR(1)
ALTAUTHREPPRESENT	CHAR(1)
HOSPCERTDONEAT	VARCHAR2(2)
REFERBFCOUNSELOR	CHAR(1)
HMLSCERTDONEAT	VARCHAR2(2)

Data Information – Multiple risk factors for each certification

RiskFactor	
<b>CERTIFICATIONID(PK) NOT NULL</b>	<b>NUMBER(10)</b>
<b>RISKFACTORID(PK) NOT NULL</b>	<b>VARCHAR2(3)</b>
SYSTEMASSIGNED	CHAR(1)
HIGHRISK	CHAR(1)
CREATEUSERID	VARCHAR2(10)
CREATEDATE	DATE
CREATETIME	VARCHAR2(8)
MODIFYUSERID	VARCHAR2(10)
MODIFYDATE	DATE
MODIFYTIME	VARCHAR2(8)
UPDATERECORD	VARCHAR2(1)
VENAAPPLIED	CHAR(1)
MEDICALCONDITION	CHAR(1)

RiskFactor_Reference	
RISKFACTORID	Not Null VARCHAR2(3)
WICSTATUS	Not Null VARCHAR2(1)
AGECATEGORYID	Not Null VARCHAR2(1)
BFAMOUNT	VARCHAR2(1)
PRIORITY	VARCHAR2(1)
HIGHRISK	Not Null CHAR(1)
DESCRIPTION	VARCHAR2(60)
CPAASSIGNED	Not Null VARCHAR2(1)
DEFAULTFOODPACKAGEID	NUMBER(10)
DFPPRIORITY	VARCHAR2(1)
DEFAULTASSESSMENT	VARCHAR2(4000)
DEFAULTPLAN	VARCHAR2(4000)

Data Information – Each State WIC ID is unique within participation months by program code (WIC or Farmer's Mrkt).

CaseLoadCount	
<b>PARTICIPATION_CYM(PK)</b>	<b>Not Null NUMBER(6)</b>
<b>STATEWICID(PK)</b>	<b>Not Null VARCHAR2(8)</b>
<b>PROGRAMCODE(PK)</b>	<b>Not Null CHAR(1)</b>
AGENCYID	Not Null VARCHAR2(3)
SERVICESITE	Not Null VARCHAR2(3)
WICSTATUS	Not Null CHAR(1)
PRIORITY	Not Null CHAR(1)
SUBPRIORITY	CHAR(1)
COUNT_FI_ISSUED	NUMBER(10)
COUNT_FI_ISSUED_REBATE	NUMBER(10)
COUNT_FI_PRESENTED	NUMBER(10)
COUNT_FI_REDEEMED	NUMBER(10)
COUNT_FI_REDEEMED_REBATE	NUMBER(10)
COUNT_FI_VOIDED	NUMBER(10)
COUNT_FI_UNREDEEMED_NOT_VOIDED	NUMBER(10)
SUM_FI_REDEEMED	NUMBER(12,2)
SUM_FI_REDEEMED_REBATE	NUMBER(12,2)
RPTED_THIS_MONTH	CHAR(1)
RDMD_THIS_MONTH	CHAR(1)
COUNT_FI_REJECTED	NUMBER(10)
PROCESS_NBR	NUMBER(10)
CREATEUSERID	VARCHAR2(10)
CREATEDATE	DATE
MODIFYUSERID	VARCHAR2(10)
MODIFYDATE	DATE
BFAMOUNT	VARCHAR2(1)

Data Table – This is the pregnancy record(s) of each mother which can be tied to the **Certcontact** table using the PregnancyID

Pregnancy	
<b>PREGNANCYID(PK)</b>	<b>Not Null NUMBER(10)</b>
STATEWICID	Not Null VARCHAR2(8)
PREGRCDDATE	Not Null DATE
LMPSTART	DATE
LASTPREGEND	VARCHAR2(6)
EXPDELIVDATE	DATE
EXPECTMULTIPLEBIRTHS	VARCHAR2(1)
NUMBEROFPREGNANCIES	NUMBER(2)
NUMBERWICPREGNANCIES	NUMBER(2)
NUMBERLIVEBIRTHS	NUMBER(2)
NOPRENATALCARE	CHAR(1)
PRENATALCAREBEGAN	VARCHAR2(6)
PREPREGWEIGHT	NUMBER(3)
FEEDINGMETHODCODE	VARCHAR2(1)
PLANNEDCSECTION	CHAR(1)
EATINGNONFOODITEMS	CHAR(1)
ENVIRONMENTALSMOKE	CHAR(1)
PREPREGCIGSDAY	NUMBER(2)
PREPREGALCDAYSWEEK	NUMBER(1)
PREPREGDRINKSDAY	NUMBER(2)
CURCIGSDAY	NUMBER(2)
CURALCDAYSWEEK	NUMBER(1)
CURDRINKSDAY	NUMBER(2)
LAST3CIGSDAY	NUMBER(2)
LAST3ALCDAYSWEEK	NUMBER(1)
LAST3DRINKSDAY	NUMBER(2)
PPCIGSDAY	NUMBER(2)
PPALCDAYSWEEK	NUMBER(1)
PPDRINKSDAY	NUMBER(2)
SMOKINGCHANGE	VARCHAR2(1)
SMOKINGCHANGEPP	VARCHAR2(1)
NOPRENATALCAREPP	VARCHAR2(1)
PRENATALCAREBEGANPP	VARCHAR2(6)
WEIGHTGAINED	NUMBER(3)
CSECTION	CHAR(1)
ONWICDURINGPREGNANCY	CHAR(1)
ACTDELIVDATE	DATE
WEIGHTATDELIVERY	NUMBER(3)
DISCHARGEDATE	DATE
BIRTHINGFACILITY	VARCHAR2(5)
EDUCATIONLEVEL	VARCHAR2(1)
MARITALSTATUS	VARCHAR2(1)
CONCEPTIONAGE	NUMBER(2)
LOWBIRTHWEIGHT	CHAR(1)
PREMATUREBIRTH	CHAR(1)
NEONATALDEATH	CHAR(1)
INFODATE	DATE
CREATEUSERID	VARCHAR2(10)
CREATEDATE	DATE
CREATETIME	VARCHAR2(8)
MODIFYUSERID	VARCHAR2(10)
MODIFYDATE	DATE
MODIFYTIME	CHAR(10)
UPDATERECORD	VARCHAR2(1)
CDCREPORTEDDT	DATE
HOUSEHOLDSTMOKING	VARCHAR2(1)
HOUSEHOLDSTMOKINGPP	VARCHAR2(1)
MULTIVITAMINBEFOREPREG	VARCHAR2(1)
MULTIVITAMINDURINGPREG	VARCHAR2(1)
PARITY	NUMBER(2)
PREPREGDRINKSWEEK	NUMBER(2)
CURDRINKSWEEK	NUMBER(2)
LAST3DRINKSWEEK	NUMBER(2)
PPCURDRINKSWEEK	NUMBER(2)
BFPEERCOUNSELREFERDATE	DATE

Data Table – General Information about each woman. Every woman in the WIC program will be in this table

Woman	
<b>STATEWICID(PK)</b>	<b>Not Null VARCHAR2(8)</b>
LOWBIRTHWEIGHT	CHAR(1)
PREMATUREBIRTH	CHAR(1)
NEONATALDEATH	CHAR(1)
CREATIONUSERID	VARCHAR2(10)
CREATEDATE	DATE
CREATETIME	VARCHAR2(8)
MODIFYUSERID	VARCHAR2(10)
MODIFYDATE	DATE
MODIFYTIME	VARCHAR2(8)
UPDATERECORD	VARCHAR2(1)

## Pregnancy, Child, Infantpregnancy, and Woman tables

Data Table – Contains the infant's information and is tied to the mother by the Pregnancy ID found in the **Certcontact** table. The Breastfeeding amount found in this table is used to determine the MOTHER'S Breastfeeding amount because this is what the mother is actually BF the infant. All infants found in this table will also be in the **Child** table as well.

InfantPregnancy	
<b>PREGNANCYID(PK)</b>	<b>Not Null NUMBER(10)</b>
<b>INFANTNUMBER(PK)</b>	<b>Not Null NUMBER(10)</b>
STATEWICID	VARCHAR2(8)
GENDER	VARCHAR2(1)
STATUSPPVISIT	VARCHAR2(1)
WEIGHTLBS	NUMBER(3)
WEIGHTOUNCES	NUMBER(2)
LENGHTINCHES	NUMBER(2)
LENGTHEIGHTHS	NUMBER(1)
EVERBREASTFED	VARCHAR2(1)
CURRENTLYBREASTFED	CHAR(1)
AMOUNTBREASTFEEDING	VARCHAR2(1)
BREASTFEEDINGEND	DATE
STOPPEDBFREASON	VARCHAR2(1)
AGEINTROFORMULA	VARCHAR2(1)
CREATEUSERID	VARCHAR2(10)
CREATEDATE	DATE
CREATETIME	VARCHAR2(8)
MODIFYUSERID	VARCHAR2(10)
MODIFYDATE	DATE
MODIFYTIME	VARCHAR2(8)
UPDATERECORD	VARCHAR2(1)
BFVERIFIEDDATE	DATE
SUPPFEEDBEGANDATE	DATE

Data Table – Mother and child are tied together using this table. The BF amount in this table is what is used to determine the BF amount of the infant or child. All infants and children will be found in this table

Child	
<b>STATEWICID(PK)</b>	<b>Not Null VARCHAR2(8)</b>
MOTHERSTATEWICID	VARCHAR2(8)
EVERBREASTFED	VARCHAR2(1)
CURRENTLYBREASTFED	CHAR(1)
AMOUNTBREASTFEEDING	VARCHAR2(1)
BREASTFEEDINGEND	DATE
STOPPEDBFREASON	VARCHAR2(1)
BFINFORMATIONDATE	DATE
AGEINTROFORMULA	VARCHAR2(1)
MULTIPLEBIRTH	VARCHAR2(1)
WEIGHTPOUNDS	NUMBER(3)
WEIGHTOUNCES	NUMBER(2)
LENGHTINCHES	NUMBER(2)
LENGTHEIGHTHS	NUMBER(1)
PREMATUREBIRTH	CHAR(1)
WEEKSGESTATION	NUMBER(2)
MOTHERDOB	DATE
BIRTHINGFACILITY	VARCHAR2(5)
IMMUNIZATIONCONSENT	CHAR(1)
REGISTRYID	VARCHAR2(15)
IMMUNIZATIONSTATUS	VARCHAR2(1)
IMMUNIZATIONSTATUSUPDATEDDATE	DATE
REFUSEDVACCINATIONREASON	CHAR(1)
FOSTERPARENTS	CHAR(1)
CREATEUSERID	VARCHAR2(10)
CREATEDATE	DATE
MODIFYUSERID	VARCHAR2(10)
MODIFYDATE	DATE
UPDATERECORD	VARCHAR2(1)
CREATETIME	VARCHAR2(8)
MODIFYTIME	VARCHAR2(8)
IMMUNIZATIONSTATUSSOURCE	CHAR(1)
BFVERIFIEDDATE	DATE
BFVERIFIEDUPDATEDDATE	DATE
SUPPFEEDBEGANDATE	DATE
TVVIDEOVIEWING	VARCHAR2(1)
HOUSEHOLDSTMOKING	VARCHAR2(1)



# AnthropContact and Bloodwork tables

Data Information - Height and weight information is found in this table for all participants

ANTHROPCONTACT	
<b>STATEWICID(PK) Not Null</b>	<b>VARCHAR2(8)</b>
<b>MEASUREMENTDATE(PK) Not Null</b>	<b>DATE</b>
CERTSTARTDATE	DATE
LENGTHINCHES	NUMBER(3)
LENGTHHEIGHTS	NUMBER(1)
RECUMBENT	VARCHAR2(1)
WEIGHTPOUNDS	NUMBER(3)
WEIGHTOUNCES	NUMBER(2)
INCORRECTREASON	VARCHAR2(1)
WICSTATUS	VARCHAR2(1)
CREATEUSERID	VARCHAR2(10)
CREATEDATE	DATE
CREATETIME	VARCHAR2(8)
MODIFYUSERID	VARCHAR2(10)
MODIFYDATE	DATE
MODIFYTIME	VARCHAR2(8)
UPDATERECORD	VARCHAR2(1)

Data Information - Blood work information is found in this table. Infants less than 9 months old will typically not have any blood work done

BLOODWORK	
<b>STATEWICID(PK) Not Null</b>	<b>VARCHAR2(8)</b>
<b>RESULTDATE(PK) Not Null</b>	<b>DATE</b>
CERTSTARTDATE	DATE
HEMATOCRIT	NUMBER(3,1)
HEMOGLOBIN	NUMBER(3,1)
LEAD	NUMBER(3,1)
EP	NUMBER(3)
EXCEPTIONREASON	VARCHAR2(1)
WICSTATUS	VARCHAR2(1)
DELAYEDBLOODWORK	CHAR(1)
CREATEUSERID	VARCHAR2(10)
CREATEDATE	DATE
CREATETIME	VARCHAR2(8)
MODIFYUSERID	VARCHAR2(10)
MODIFYDATE	DATE
MODIFYTIME	VARCHAR2(8)
UPDATERECORD	VARCHAR2(1)
ACTUALBLOODWORKDATE	DATE

## ReferenceDictionary Tables

Reference Tables – These tables contain most of the descriptions found throughout the application. It can be a little challenging sometimes to hunt down what code should be used for which description, but it's generally not too hard. The Descriptions found in the RefDictionaryCategory are very helpful. Once you find the correct category in the RefDictionaryCategory table, you can tie the information to the ReferenceDictionary table using the category to get the items' descriptions.

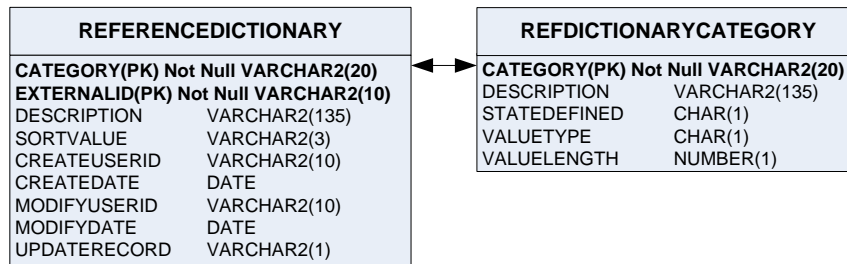

## CaseLoadCount tables

Data Table – This is a month end table containing summary participant information. These are participation counts/sums by **statewcid/YYYYMM/Program Code**

CASELOADCOUNT		
PARTICIPATION_CYM(PK)	Not Null	NUMBER (6)
STATEWICID(PK)	Not Null	VARCHAR2 (8)
PROGRAMCODE(PK)	Not Null	CHAR (1)
AGENCYID	Not Null	VARCHAR2 (3)
SERVICESTATE	Not Null	VARCHAR2 (3)
WICSTATUS	Not Null	CHAR (1)
PRIORITY	Not Null	CHAR (1)
SUBPRIORITY		CHAR (1)
COUNT_FL_ISSUED		NUMBER (10)
COUNT_FL_ISSUED_REBATE		NUMBER (10)
COUNT_FL_PRESENTED		NUMBER (10)
COUNT_FL_REDEEMED		NUMBER (10)
COUNT_FL_REDEEMED_REBATE		NUMBER (10)
COUNT_FL_VOIDED		NUMBER (10)
COUNT_FL_UNREDEEMED_NOT_VOIDED		NUMBER (10)
SUM_FL_REDEEMED		NUMBER (12,2)
SUM_FL_REDEEMED_REBATE		NUMBER (12,2)
RPTD_THIS_MONTH		CHAR (1)
RDMD_THIS_MONTH		CHAR (1)
COUNT_FL_REJECTED		NUMBER (10)
PROCESS_NBR		NUMBER (10)
CREATEUSERID		VARCHAR2 (10)
CREATEDATE		DATE
MODIFYUSERID		VARCHAR2 (10)
MODIFYDATE		DATE
BFAMOUNT		VARCHAR2 (1)

Data Table – This is a month-end table containing summary enrollment information. These are enrolled counts/sums by **statewcid/YYYYMM/Program Code**

CASELOADCOUNTENROLLMENT		
PARTICIPATION_CYM(PK)	Not Null	NUMBER(6)
STATEWICID(PK)	Not Null	VARCHAR2(8)
PROGRAMCODE(PK)	Not Null	CHAR(1)
AGENCYID	Not Null	VARCHAR2(3)
WICSTATUS	Not Null	CHAR(1)
PRIORITY	Not Null	CHAR(1)
SUBPRIORITY		CHAR(1)
CURRENTLYBREASTFEEDING	Not Null	CHAR(1)
COUNTY		VARCHAR2(3)
LEGALMUNICIPALITY		VARCHAR2(4)
RACEETHNICITY		VARCHAR2(3)
MIGRANT		CHAR(1)
ORIG_ENROLLEMENT_DATE		NUMBER(6)
CURRENT_EFFECTIVE_DATE		NUMBER(6)
CURRENT_END_DATE		NUMBER(6)
TERMINATION_DATE		NUMBER(6)
REINSTATEMENTDATE		NUMBER(6)
CATEGORICALLY_INELIGIBLE_DATE		NUMBER(6)
PREVIOUS_END_DATE_CYM		NUMBER(6)
ENROLLED_THIS_MONTH		CHAR(1)
WAIT_LIST_STATUS		VARCHAR2(1)
PROCESS_NBR		NUMBER(10)
CREATEUSERID		VARCHAR2(10)
CREATEDATE		DATE
MODIFYUSERID		VARCHAR2(10)
MODIFYDATE		DATE
SERVICESTATE	Not Null	VARCHAR2(3)
FULLYBREASTFED		VARCHAR2(1)

Data Table – This is a month-end table containing summary information for items with potential rebates. These are Rebate Items counts/sums by **statewcid/YYYYMM/Program Code**

CASELOADCOUNTREBATEITEMS		
PARTICIPATION_CYM(PK)	Not Null	NUMBER(6)
STATEWICID(PK)	Not Null	VARCHAR2(8)
PROGRAMCODE(PK)	Not Null	CHAR(1)
BASEFOODCATEGORYID(PK)	Not Null	VARCHAR2(1)
PROCESS_NBR		NUMBER(10)
REBATEISSUEDCOUNT		NUMBER(10)
REBATEREDEEMEDCOUNT		NUMBER(10)
CREATEUSERID		VARCHAR2(10)
CREATEDATE		DATE
MODIFYUSERID		VARCHAR2(10)
MODIFYDATE		DATE

Data Table – This is a month-end table containing summary unduplicated participation information for the calendar year. This table is unique by **Calendar Year/StateWICID**  
Jan - Dec

CASELOADCOUNTUNDUPCALENDAR		
FISCALYEAR(PK)	Not Null	NUMBER(4)
STATEWICID(PK)	Not Null	VARCHAR2(8)
ENROLLPART_CYM		NUMBER(6)
ENROLLPARTAGENCYID		VARCHAR2(3)
ENROLLPARTWICSTATUS		VARCHAR2(1)
ENROLLPARTPRIORITY		CHAR(1)
ENROLLPARTSUBPRIORITY		CHAR(1)
REPORTEDPART_CYM		NUMBER(6)
REPORTEDPARTAGENCYID		VARCHAR2(3)
REPORTEDPARTWICSTATUS		VARCHAR2(1)
REPORTEDPARTPRIORITY		CHAR(1)
REPORTEDPARTSUBPRIORITY		CHAR(1)
REPORTEDPARTREBATEIND		CHAR(1)
REDEEMEDPART_CYM		NUMBER(6)
REDEEMEDPARTAGENCYID		VARCHAR2(3)
REDEEMEDPARTWICSTATUS		VARCHAR2(1)
REDEEMEDPARTPRIORITY		CHAR(1)
REDEEMEDPARTSUBPRIORITY		CHAR(1)
REDEEMEDPARTREBATEIND		CHAR(1)
PROCESS_NBR		NUMBER(10)
CREATEUSERID		VARCHAR2(10)
CREATEDATE		DATE
MODIFYUSERID		VARCHAR2(10)
MODIFYDATE		DATE

Data Table – This is a month-end table containing summary unduplicated participation information for the federal fiscal year. This table is unique by **Federal Fiscal Year/StateWICID**  
Oct - Sept

CASELOADCOUNTUNDUPFEDERAL		
FISCALYEAR(PK)	Not Null	NUMBER(4)
STATEWICID(PK)	Not Null	VARCHAR2(8)
ENROLLPART_CYM		NUMBER(6)
ENROLLPARTAGENCYID		VARCHAR2(3)
ENROLLPARTWICSTATUS		VARCHAR2(1)
ENROLLPARTPRIORITY		CHAR(1)
ENROLLPARTSUBPRIORITY		CHAR(1)
REPORTEDPART_CYM		NUMBER(6)
REPORTEDPARTAGENCYID		VARCHAR2(3)
REPORTEDPARTWICSTATUS		VARCHAR2(1)
REPORTEDPARTPRIORITY		CHAR(1)
REPORTEDPARTSUBPRIORITY		CHAR(1)
REPORTEDPARTREBATEIND		CHAR(1)
REDEEMEDPART_CYM		NUMBER(6)
REDEEMEDPARTAGENCYID		VARCHAR2(3)
REDEEMEDPARTWICSTATUS		VARCHAR2(1)
REDEEMEDPARTPRIORITY		CHAR(1)
REDEEMEDPARTSUBPRIORITY		CHAR(1)
REDEEMEDPARTREBATEIND		CHAR(1)
PROCESS_NBR		NUMBER(10)
CREATEUSERID		VARCHAR2(10)
CREATEDATE		DATE
MODIFYUSERID		VARCHAR2(10)
MODIFYDATE		DATE

Data Table – This is a month-end table containing summary unduplicated participation information state fiscal year. This table is unique by **State Fiscal Year/StateWICID**  
July – June

CASELOADCOUNTUNDUPSTATE		
FISCALYEAR(PK)	Not Null	NUMBER(4)
STATEWICID(PK)	Not Null	VARCHAR2(8)
ENROLLPART_CYM		NUMBER(6)
ENROLLPARTAGENCYID		VARCHAR2(3)
ENROLLPARTWICSTATUS		VARCHAR2(1)
ENROLLPARTPRIORITY		CHAR(1)
ENROLLPARTSUBPRIORITY		CHAR(1)
REPORTEDPART_CYM		NUMBER(6)
REPORTEDPARTAGENCYID		VARCHAR2(3)
REPORTEDPARTWICSTATUS		VARCHAR2(1)
REPORTEDPARTPRIORITY		CHAR(1)
REPORTEDPARTSUBPRIORITY		CHAR(1)
REPORTEDPARTREBATEIND		CHAR(1)
REDEEMEDPART_CYM		NUMBER(6)
REDEEMEDPARTAGENCYID		VARCHAR2(3)
REDEEMEDPARTWICSTATUS		VARCHAR2(1)
REDEEMEDPARTPRIORITY		CHAR(1)
REDEEMEDPARTSUBPRIORITY		CHAR(1)
REDEEMEDPARTREBATEIND		CHAR(1)
PROCESS_NBR		NUMBER(10)
CREATEUSERID		VARCHAR2(10)
CREATEDATE		DATE
MODIFYUSERID		VARCHAR2(10)
MODIFYDATE		DATE

Data Table – A summary of enrollment (CaseLoadCountEnrollment), participation (CaseloadCount) and redemption (RedemptionReconciliation) totals at the end of the issuance month (reported month). Once the month has been reported, the values will not be adjusted to reflect additional data received in the 30-day and close-out months. It is unique by **AgencyID/ServiceSite/ReportYear/ReportMonth**

CASELOADPROJECTION		
AGENCYID(PK)	Not Null	VARCHAR2(3)
SERVICESTATE(PK)	Not Null	VARCHAR2(3)
REPORTYEAR(PK)	Not Null	VARCHAR2(4)
REPORTMONTH(PK)	Not Null	VARCHAR2(2)
ENROLLMENTCOUNTISS		NUMBER(10)
RPTDPARTISS		NUMBER(10)
RDMDPART30D		NUMBER(10)
RDMDPARTCO		NUMBER(10)
RDMDFIS30D		NUMBER(12)
RDMDFISCO		NUMBER(12)
AVGRDMDFICOST30D		NUMBER(5,2)
AVGRDMDFICOSTCO		NUMBER(5,2)
AVGRECONFICOSTISS		NUMBER(5,2)
FOODEXPCO		NUMBER(12)
CREATEUSERID		VARCHAR2(10)
CREATEDATE		DATE
MODIFYUSERID		VARCHAR2(10)
MODIFYDATE		DATE

# Income Tables

Reference - The additional income amount allowed for each household member above the eighth household member.

INCOMEADDITIONALAMOUNT		
<b>FISCALYEAR(PK)</b>	<b>Not Null</b>	<b>VARCHAR2(4)</b>
ADDITIONALAMOUNT		NUMBER(8,2)

Reference – The annual amount of income allowed for a household of the given household size

INCOMEELIGIBILITYAMOUNT		
<b>FISCALYEAR(PK)</b>	<b>Not Null</b>	<b>VARCHAR2(4)</b>
<b>HOUSEHOLDSIZE(PK)</b>	<b>Not Null</b>	<b>NUMBER(3)</b>
ANNUALAMOUNT		NUMBER(8,2)
100PERCENT		NUMBER(8,2)
125PERCENT		NUMBER(8,2)
175PERCENT		NUMBER(8,2)
185PERCENT		NUMBER(8,2)
250PERCENT		NUMBER(8,2)

Data Table - An income item is a quantity of money received at a specified interval that is reported during an income screening contact

INCOMEITEM		
<b>STATEWICID(PK)</b>	<b>Not Null</b>	<b>VARCHAR2(8)</b>
<b>SCREENDATE(PK)</b>	<b>Not Null</b>	<b>DATE</b>
<b>LINEITEMID(PK)</b>	<b>Not Null</b>	<b>NUMBER(10)</b>
FREQUENCY		VARCHAR2(1)
AMOUNT		NUMBER(7,2)
UPDATERECORD		VARCHAR2(1)
HOURSPERWEEK		NUMBER(3)
DURATION		NUMBER(2)
PROOFOFINCOME		VARCHAR2(1)

Data Table – An income screening contact is an encounter with a member where income information is collected and recorded

INCOMECONTACT		
<b>STATEWICID(PK)</b>	<b>Not Null</b>	<b>VARCHAR2(8)</b>
<b>SCREENDATE(PK)</b>	<b>Not Null</b>	<b>DATE</b>
CERTSTARTDATE		DATE
ANNUALAMOUNT		NUMBER(6)
TANF		CHAR(1)
FOODSTAMPS		CHAR(1)
MEDICAD		CHAR(1)
PRESUMPTIVEELIGIBILITYDATE		DATE
HOUSEHOLDSIZE		NUMBER(2)
CREATEUSERID		VARCHAR2(10)
CREATEDATE		DATE
CREATETIME		VARCHAR2(8)
MODIFYUSERID		VARCHAR2(10)
MODIFYDATE		DATE
MODIFYTIME		VARCHAR2(8)
UPDATERECORD		VARCHAR2(1)
ADJUNCTIVEVERIFICATIONTYP		CHAR(1)
ADJUNCTIVEVERIFICATIONNUMBER		VARCHAR2(20)

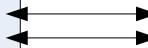

```

SELECT *
FROM foodprescription fp,
     foodrxitem fri,
     foodprescriptionitem pi,
     itempurchasesize ips,
     fooddistributionitem fdi,
     milkformulationitem mfi,
     rebate_agreement_item_rx rair,
     rebate_agreement_item rai,
     rebate_schedule rs,
     rebate_agreement ra,
     Supplier s,
     BASEFOODCATEGORY BFC
WHERE 1 = 1
AND fp.statewcid = '10042769'--Using one WIC ID as an example for this query
AND pi.foodprescriptionitem = fri.prescriptionitemid
AND pi.prescriptiondate = fp.prescriptiondate
AND pi.statewcid = fp.statewcid
AND ips.prescriptionitemid = fri.prescriptionitemid
AND fdi.distributionitemid = ips.distributionitemid
AND mfi.prescriptionitemid(+) = pi.foodprescriptionitem
AND fdi.distributionitemid = rair.distribution_item_id
AND rair.agreement_id = rai.agreement_id
AND rair.supplier_id = rai.supplier_id
AND rair.schedule_id = rai.schedule_id
AND rair.product_id = rai.product_id
AND rai.agreement_id = rs.agreement_id
AND rai.supplier_id = rs.supplier_id
AND rai.schedule_id = rs.schedule_id
AND rs.agreement_id = ra.agreement_id
AND rs.supplier_id = ra.supplier_id
AND rs.adj_effective_dt = ra.effective_dt
AND ra.effective_dt <= pi.prescriptiondate
AND ra.expiration_dt > pi.prescriptiondate
AND RA.SUPPLIER_ID = S.SUPPLIER_ID
AND RA.BASE_FOOD_CATEGORY_ID = BFC.BASEFOODCATEGORYID

```

Using the Distribution\_Item\_ID in the **REBATE\_AGREEMENT\_ITEM\_RX** table can allow you to derive Rebate items from the food prescription items if needed using the tables found with the FOODDISTRIBUTIONITEM table. Here's an example of what a join between the rebate tables and FoodPrescription tables would look like

BASEFOODCATEGORY	
<b>BASEFOODCATEGORYID(PK)</b> Not Null	VARCHAR2 (1)
DESCRIPTION	VARCHAR2 (30)

SUPPLIER	
<b>SUPPLIER_ID(PK)</b> Not Null	NUMBER (10)
SUPPLIER_NAME	Not Null VARCHAR2 (50)
ADDRESS_1	VARCHAR2 (50)
ADDRESS_2	VARCHAR2 (50)
CITY	VARCHAR2 (30)
STATE_CD	VARCHAR2 (2)
ZIP_CD	VARCHAR2 (9)
TELEPHONE_NBR	VARCHAR2 (20)
FAX_NBR	VARCHAR2 (20)
FEDERAL_TAX_ID	VARCHAR2 (9)
STATUS_CD	VARCHAR2 (2)
REMARKS	VARCHAR2 (1000)
CREATE_USER_ID	VARCHAR2 (10)
CREATE_DATE	DATE
MODIFY_USER_ID	VARCHAR2 (10)
MODIFY_DATE	DATE
CONTACT_SALUTATION	VARCHAR2 (5)
CONTACT_FIRST_NAME	VARCHAR2 (20)
CONTACT_LAST_NAME	VARCHAR2 (25)

REBATE_SCHEDULE	
<b>AGREEMENT_ID(PK)</b> Not Null	NUMBER (10)
<b>SUPPLIER_ID(PK)</b> Not Null	NUMBER (10)
<b>SCHEDULE_ID(PK)</b> Not Null	NUMBER (10)
<b>ADJ_EFFECTIVE_DT</b> Not Null	DATE
CREATE_USER_ID	VARCHAR2 (10)
CREATE_DATE	DATE
MODIFY_USER_ID	VARCHAR2 (10)
MODIFY_DATE	DATE

REBATE_AGREEMENT	
<b>AGREEMENT_ID(PK)</b> Not Null	NUMBER(10)
<b>SUPPLIER_ID(PK)</b> Not Null	NUMBER(10)
<b>BASE_FOOD_CATEGORY_ID</b> Not Null	VARCHAR2(1)
AGREEMENT_TITLE	Not Null VARCHAR2(120)
<b>EFFECTIVE_DT</b> Not Null	DATE
<b>EXPIRATION_DT</b> Not Null	DATE
BILL_TO_ADDRESS_1	VARCHAR2(50)
BILL_TO_ADDRESS_2	VARCHAR2(50)
BILL_TO_CITY	VARCHAR2(30)
BILL_TO_STATE	VARCHAR2(2)
BILL_TO_ZIP_CD	VARCHAR2(9)
TELEPHONE_NBR	VARCHAR2(20)
FAX_NBR	VARCHAR2(20)
CONTRACT_BASIS_CD	VARCHAR2(1)
ADJ_METHOD_IND	VARCHAR2(1)
CREATE_USER_ID	VARCHAR2(10)
CREATE_DATE	DATE
MODIFY_USER_ID	VARCHAR2(10)
MODIFY_DATE	DATE
CONTACT_SALUTATION	VARCHAR2 (5)
CONTACT_FIRST_NAME	VARCHAR2 (20)
CONTACT_LAST_NAME	VARCHAR2 (25)

REBATE_AGREEMENT_ITEM	
<b>AGREEMENT_ID(PK)</b> Not Null	NUMBER (10)
<b>SUPPLIER_ID(PK)</b> Not Null	NUMBER (10)
<b>SCHEDULE_ID(PK)</b> Not Null	NUMBER (10)
<b>PRODUCT_ID(PK)</b> Not Null	NUMBER (10)
REBATE_PER_UNIT	Not Null NUMBER (9,5)
CREATE_USER_ID	VARCHAR2 (10)
CREATE_DATE	DATE
MODIFY_USER_ID	VARCHAR2 (10)
MODIFY_DATE	DATE

REBATE_AGREEMENT_ITEM_RX	
<b>AGREEMENT_ID(PK)</b> Not Null	NUMBER (10)
<b>SUPPLIER_ID(PK)</b> Not Null	NUMBER (10)
<b>SCHEDULE_ID(PK)</b> Not Null	NUMBER (10)
<b>PRODUCT_ID(PK)</b> Not Null	NUMBER (10)
<b>DISTRIBUTION_ITEM_ID(PK)</b> Not Null	VARCHAR2 (10)
CREATE_USER_ID	VARCHAR2 (10)
CREATE_DATE	DATE
MODIFY_USER_ID	VARCHAR2 (10)
MODIFY_DATE	DATE

MANUFACTURER_PRODUCT	
<b>SUPPLIER_ID(PK)</b> Not Null	NUMBER (10)
<b>PRODUCT_ID(PK)</b> Not Null	NUMBER (10)
UOM_CD	Not Null VARCHAR2 (3)
BASE_FOOD_CATEGORY_ID	Not Null VARCHAR2 (1)
PRODUCT_DESC	Not Null VARCHAR2 (100)
UPC	VARCHAR2 (30)
CREATE_USER_ID	VARCHAR2 (10)
CREATE_DATE	DATE
MODIFY_USER_ID	VARCHAR2 (10)
MODIFY_DATE	DATE

**NOTE: These tables exist, but ARE NOT USED and have NO date in them:**  
 REBATE\_ACCOUNT\_TRANSACTION  
 REBATE\_INVOICE  
 REBATE\_INVOICE\_ITEM

Member data is unique

MEMBER	
STATEWICID(PK)	VARCHAR2(8)
MEDICALHOMEID	NUMBER(10)
HOUSEHOLDID	VARCHAR2(8)
AGENCYID	VARCHAR2(3)
SERVICESTEID	VARCHAR2(3)
RESOURCEID	NUMBER(10)
APPLICATIONDATE	DATE
LASTNAME	VARCHAR2(25)
FIRSTNAME	VARCHAR2(20)
MIDDLEINITIAL	VARCHAR2(1)
DATEOFBIRTH	DATE
GENDER	VARCHAR2(1)
RACEETHNICITY	VARCHAR2(2)
MOTHERFIRSTNAME	VARCHAR2(20)
MOTHERMIDDLEINITIAL	VARCHAR2(1)
MOTHERLASTNAME	VARCHAR2(25)
RESIDENCYPROOF	VARCHAR2(1)
IDENTIFICATIONPROOF	VARCHAR2(1)
DISABILITY	VARCHAR2(1)
HARDSHIP1	VARCHAR2(1)
HARDSHIP2	VARCHAR2(1)
HARDSHIP3	VARCHAR2(1)
HARDSHIP4	VARCHAR2(1)
HARDSHIP5	VARCHAR2(1)
HARDSHIP6	VARCHAR2(1)
INSURANCETYPE	VARCHAR2(1)
MEDICALHOMETYPE	VARCHAR2(1)
ISSUANCEFREQUENCY	VARCHAR2(1)
FOLLOWUPFREQUENCY	VARCHAR2(1)
FOLLOWUPMETHOD	VARCHAR2(1)
FOLLOWUPTOPIC	VARCHAR2(3)
HIGHRISK	CHAR(1)
TERMINATED	CHAR(1)
TERMINATEDDATE	DATE
WICSTATUS	VARCHAR2(1)
MEDICAID	CHAR(1)
SSN	VARCHAR2(9)
CATEGORICALINELIGIBILITYDATE	DATE
ONPREMISESTIME	VARCHAR2(4)
WAITLISTBEGINDATE	DATE
WAITLISTENDDATE	DATE
WAITLISTNOTICEQUEUED	CHAR(1)
REINSTATENOTICEQUEUED	CHAR(1)
TRANSFERPENDING	CHAR(1)
BELONGSTOSERVER	CHAR(1)
QTRANSFERADMINISITEID	VARCHAR2(3)
QTRANSFERSVCSITEID	VARCHAR2(3)
EDUCATIONLEVEL	VARCHAR2(1)
MARITALSTATUS	VARCHAR2(1)
AUTHREPLASTNAME	VARCHAR2(25)
AUTHREPFIRSTNAME	VARCHAR2(20)
AUTHREPMIDDLEINITIAL	VARCHAR2(1)
ALTAUTHREPLASTNAME	VARCHAR2(25)
ALTAUTHREPFIRSTNAME	VARCHAR2(20)
ALTAUTHREPMIDDLEINITIAL	VARCHAR2(1)
PROXYLASTNAME	VARCHAR2(25)
PROXYFIRSTNAME	VARCHAR2(20)
PROXYMIDDLEINITIAL	VARCHAR2(1)
VOCDOCUMENT	CHAR(1)
VALIDCERTIFICATION	CHAR(1)
CERTSTARTDATE	DATE
CERTIFICATIONDUEDATE	DATE
NPNOTICEPRINTED	CHAR(1)
STATEFMELEGIBILITY	CHAR(1)
QUEUEDINELIGIBILITYDATE	DATE
CREATEUSERID	VARCHAR2(10)
CREATEDATE	DATE
CREATETIME	VARCHAR2(8)
MODIFYUSERID	VARCHAR2(10)
MODIFYDATE	DATE
MODIFYTIME	VARCHAR2(8)
UPDATERECORD	VARCHAR2(1)
LASTFMCHECKLDTU	DATE
LASTCHECKLDTU	DATE
QUEUEDINELIGIBILITYNOTICE	CHAR(1)
QTRANSFERAGENCYID	VARCHAR2(3)
PRINTVOTERFORM	VARCHAR2(1)
RACEETHNICITY2	VARCHAR2(3)
PREVIOUSLYONWIC	VARCHAR2(1)
PREVIOUSWICSTATECD	VARCHAR2(2)
PREVIOUSLYONWICDATE	VARCHAR2(6)
AUTHREPPRESENT	CHAR(1)
ALTAUTHREPPRESENT	CHAR(1)
REAPPLICATIONDATE	DATE
MIGRANT	CHAR(1)
HOMELESS	CHAR(1)

Data Information – Multiple certs for each State WIC ID in Member Table

Certcontact table	
CERTIFICATIONID(PK) NOT NULL	NUMBER(10)
PREGNANCYID	NUMBER(10)
STATEWICID	NOT NULL VARCHAR2(8)
CERTSTARTDATE	NOT NULL DATE
CERTEFFECTIVEDATE	DATE
CERTENDDATE	DATE
CERTTERMDATE	DATE
CERTTERMREASON	VARCHAR2(1)
VOCDOCUMENT	CHAR(1)
CERTINELIGIBLEDATE	DATE
CERTINELIGIBLEREASON	VARCHAR2(1)
CERTASSIGNEDPRIORITY	VARCHAR2(1)
CERTSERVICESITEID	VARCHAR2(3)
AGENCYID	VARCHAR2(3)
MANUALCERT	CHAR(1)
MANUALCERTREASON	VARCHAR2(2)
CERTWICSTATUS	VARCHAR2(1)
CREATEUSERID	VARCHAR2(10)
CREATEDATE	DATE
CREATETIME	VARCHAR2(8)
MODIFYUSERID	VARCHAR2(10)
MODIFYDATE	DATE
MODIFYTIME	VARCHAR2(8)
UPDATERECORD	VARCHAR2(1)
CERTASSIGNEDSUBPRIORITY	VARCHAR2(1)
CERTAGENCYID	VARCHAR2(3)
SERVICESTEID	VARCHAR2(3)
MANUALCHECKSISSUED	CHAR(1)
PHYSICALLYPRESENT	VARCHAR2(1)
CDCREPORTEDDT	DATE
INFORELEASESIGNED	VARCHAR2(1)
REAPPLICATIONNOTICEPRODUCED	VARCHAR2(1)
REASONNOTPHYSPRESENT	CHAR(1)
AUTHREPPRESENT	CHAR(1)
ALTAUTHREPPRESENT	CHAR(1)
HOSPCERTDONEAT	VARCHAR2(2)
REFERBFCOUNSELOR	CHAR(1)
HMLSCERTDONEAT	VARCHAR2(2)

Data Information – Multiple risk factors for each certification

RiskFactor	
CERTIFICATIONID(PK) NOT NULL	NUMBER(10)
RISKFACITORID(PK) NOT NULL	VARCHAR2(3)
SYSTEMASSIGNED	CHAR(1)
HIGHRISK	CHAR(1)
CREATEUSERID	VARCHAR2(10)
CREATEDATE	DATE
CREATETIME	VARCHAR2(8)
MODIFYUSERID	VARCHAR2(10)
MODIFYDATE	DATE
MODIFYTIME	VARCHAR2(8)
UPDATERECORD	VARCHAR2(1)
VENAAPPLIED	CHAR(1)
MEDICALCONDITION	CHAR(1)

Reference Information – RF ID has one description, but multiple records because of BF amts, WICStatus, and Age Category.

RiskFactor_Reference	
RISKFACITORID(PK) Not Null	VARCHAR2(3)
WICSTATUS(PK) Not Null	VARCHAR2(1)
AGECATEGORYID(PK) Not Null	VARCHAR2(1)
BFAMOUNT(PK) Not Null	VARCHAR2(1)
PRIORITY	VARCHAR2(1)
HIGHRISK	Not Null CHAR(1)
DESCRIPTION	VARCHAR2(60)
CPAASSIGNED	Not Null VARCHAR2(1)
DEFAULTFOODPACKAGEID	NUMBER(10)
DFPPRIORITY	VARCHAR2(1)
DEFAULTASSESSMENT	VARCHAR2(4000)
DEFAULTPLAN	VARCHAR2(4000)

Reference Information

AGENCY	
AGENCYID(PK)	VARCHAR2(3)
FAIRHEARINGOFFICERNAME	VARCHAR2(50)
FAIRHEARINGOFFICERTELEPHONE	VARCHAR2(10)
NAME	VARCHAR2(50)
ADDRESS	VARCHAR2(50)
CITY	VARCHAR2(30)
ZIP	VARCHAR2(9)
TELEPHONE	VARCHAR2(20)
HIDDENAGENCY	CHAR(1)
STATEWIDE	CHAR(1)

Reference Information

SERVICESITE	
AGENCYID(PK1)	VARCHAR2(3)
SERVICESTEID(PK2)	VARCHAR2(3)
SATELLITESERVERID	NUMBER(10)
COUNTY	VARCHAR2(3)
AREACODE	VARCHAR2(3)
ISSUANCEFREQUENCY	VARCHAR2(1)
FOLLOWUPMETHOD	VARCHAR2(1)
FOLLOWUPFREQUENCY	VARCHAR2(1)
INTROJUICE	VARCHAR2(1)
CHECKSREQUIRED	NUMBER(4)
DEFAULTLANGUAGE	VARCHAR2(1)
CHECKEDOUT	CHAR(1)
SERVICESTENAME	VARCHAR2(50)
ADDRESS1	VARCHAR2(50)
CITY	VARCHAR2(30)
ZIPCODE	VARCHAR2(9)
TELEPHONE	VARCHAR2(20)
ADMINISTRATIONSITEID	VARCHAR2(3)
EMAILADDRESS	VARCHAR2(100)
ACTIVE	CHAR(1)
APPTVIEWDURATION	NUMBER(10)

Reference Information

COUNTY	
HEALTHCOUNTYID(PK) Not Null	VARCHAR2(3)
NAME	VARCHAR2(30)
FIPSCODE	VARCHAR2(4)
STATECD	Not Null VARCHAR2(2)

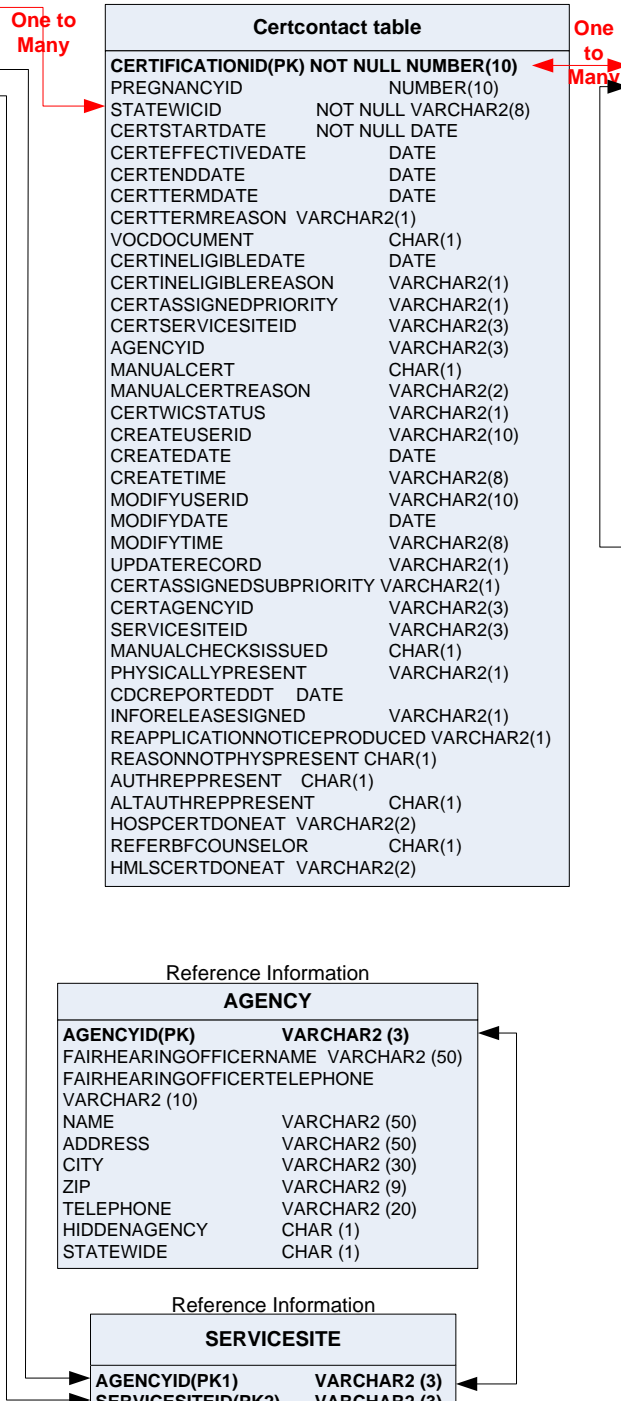

# Vendor Events and Activities tables

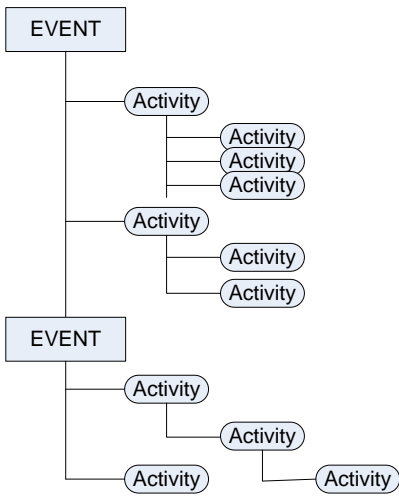

EVENT	
<b>EVENTID(PK)</b>	<b>NUMBER (10) Not Null</b>
VENDORID	VARCHAR2 (6)
DESCRIPTION	VARCHAR2 (70)
STARTDATE	DATE
TYPE	NUMBER (3)
SANCTIONPOINTSNUMBER	NUMBER (3)
CREATEUSERID	VARCHAR2 (10)
CREATEDATE	DATE
UPDATERECORD	VARCHAR2 (1)
ACTIONDATE	DATE
STAFFID	VARCHAR2 (10)
APPLYUPTO	DATE

EVENTRELATIONSHIP	
<b>EVENTID(PK)</b>	<b>NUMBER(10) Not Null</b>
<b>FOLLOWUPACTIVITYID(PK)</b>	<b>NUMBER(10) Not Null</b>
[EVENTTYPE	NUMBER(3)] meaningless
UPDATERECORD	VARCHAR2(1)

FOLLOWUPACTIVITY	
<b>FOLLOWUPACTIVITYID(PK)</b>	<b>NUMBER (10) Not Null</b>
VENDORID	VARCHAR2 (6) Not Null
STARTDATE	DATE
TYPE	NUMBER (3)
SANCTIONPOINTSNUMBER	NUMBER (3)
CREATEUSERID	VARCHAR2 (10)
CREATEDATE	DATE
UPDATERECORD	VARCHAR2 (1)
ACTIONDATE	DATE
STAFFID	VARCHAR2 (10)
APPLYUPTO	DATE

VIOLATION	
<b>VIOLATIONID(PK)</b>	<b>NUMBER(10)</b>
STAFFID	VARCHAR2(10)
VENDORID	VARCHAR2(6)
IDENTIFIEDDATE	DATE
OCCURREDDATE	DATE
VIOLATIONTYPE	VARCHAR2(3)
MONITORINGAREA	CHAR(1)
SANCTIONPOINTSNUMBER	NUMBER(3)
CHECKSERIALNUMBER	VARCHAR2(8)
CREATEUSERID	VARCHAR2(10)
CREATEDATE	DATE
UPDATERECORD	VARCHAR2(1)
ACTIONDATE	DATE
VIOLATIONSOURCE	VARCHAR2(4000)
APPLYUPTO	DATE

MONITORINGVISIT	
VENDORID	VARCHAR2(6) Not Null
<b>MONITORINGVISITID(PK)</b>	<b>NUMBER(10) Not Null</b>
STAFFID	VARCHAR2(10) Not Null
VISITDATE	DATE
CREATEUSERID	VARCHAR2(10)
CREATEDATE	DATE
UPDATERECORD	VARCHAR2(1)
ACTIONDATE	DATE
COMMENTS	VARCHAR2(4000)
PHYSICALLYONSITE	VARCHAR2(1)
RECOMMENDCOMPBUY	VARCHAR2(1)

MONITORINGVISITREASON	
<b>MONITORINGVISITID(PK)</b>	<b>NUMBER(10)</b>
<b>REASONCODE(PK)</b>	<b>VARCHAR2(3)</b>
CREATEUSERID	VARCHAR2(10)
CREATEDATE	DATE
UPDATERECORD	VARCHAR2(1)

FOLLOWUPRELATIONSHIP	
<b>PARENTFOLLOWUPACTIVITYID(PK)</b>	<b>NUMBER(10) Not Null</b>
<b>CHILDFOLLOWUPACTIVITYID(PK)</b>	<b>NUMBER(10) Not Null</b>
[CHILDFOLLOWUPACTIVITYTYPE	NUMBER(3)] meaningless
UPDATERECORD	VARCHAR2(1)

FINALDISPOSITION	
VENDORID	VARCHAR2 (6)
<b>FINALDISPOSITIONID(PK)</b>	<b>Not Null NUMBER (10)</b>
FINALDISPOSITIONDATE	DATE
OUTCOME	VARCHAR2 (2)
REMOVEDSANCTIONPOINTS	CHAR (1)
POINTSREMOVED	NUMBER (3)
CREATEUSERID	VARCHAR2 (10)
CREATEDATE	DATE
UPDATERECORD	VARCHAR2 (1)
ACTIONDATE	DATE
COMMENTS	VARCHAR2 (4000)

VIOLATIONTYPE	
<b>CATEGORY(PK)</b>	<b>VARCHAR2(20)</b>
<b>VIOLATIONTYPEID(PK)</b>	<b>VARCHAR2(3)</b>
DESCRIPTION	VARCHAR2(135)
SANCTIONPOINTSNUMBER	NUMBER(3)
SORTVALUE	VARCHAR2(3)
CREATEUSERID	VARCHAR2(10)
CREATEDATE	DATE
MODIFYUSERID	VARCHAR2(10)
MODIFYDATE	DATE
UPDATERECORD	VARCHAR2(1)
DAYSTOAPPLY	NUMBER(5)
USEFORMULA	CHAR(1)
DAYSDQ	NUMBER(5)

A "Y" in Violation MONITORINGAREA = "MONITORAREA" Category in ViolationType  
 An "N" in Violation MONITORINGAREA = "VIOLATIONTYPE" Category in ViolationType

# Rhode Island EBT/UPC tables

EBTAUTHORIZEDUPC
<b>UPCCD(PK) VARCHAR2 (20) Not Null</b>
<b>STATECD(PK) VARCHAR2 (2) Not Null</b>
UPCDESCRIPTION VARCHAR2 (50) Not Null
UNITOFMEASURECD VARCHAR2 (6) Not Null
UPCPACKAGESIZEUNITS NUMBER (5,2) Not Null
QUANTITY NUMBER (5,2) Not Null
ALLOWABLE CHAR (1) Not Null
STARTDATE DATE Not Null
ENDDATE DATE Not Null
PLUIND CHAR (1)
CREATEUSERID VARCHAR2 (20)
CREATEDTTM DATE
MODIFYUSERID VARCHAR2 (20)
MODIFYDTTM DATE
DISTRIBUTIONITEMID NUMBER (18)
FOODCATEGORYCD CHAR (2)
FOODSUBCATEGORYCD CHAR (3)
BENEFITUNIT VARCHAR2 (50)
ITEMPRICE NUMBER (6,2)
PRICETYPE VARCHAR2 (2)
CARDACCEPTORIDENTIFICATIONCODE VARCHAR2 (15)
PURCHASEINDICATOR NUMBER (1)
UPCPLUDATALLENGTH VARCHAR2 (2)
REBATEITEM VARCHAR2 (1)
SHORTPRODUCTDESCRIPTION VARCHAR2 (24)
PRODUCTSTATUS CHAR (1)
PRESCRIPTIONREQUIRED CHAR (1)
MANUALAUTHORIZATIONFLAG CHAR (1)
INCLUDEININVENTORYAUDIT VARCHAR2 (1)

EBTFOODCATSUBCATEGORY
<b>FOODCATEGORYCD (PK) CHAR (2) Not Null</b>
<b>FOODSUBCATEGORYCD (PK) CHAR (3) Not Null</b>
FOODCATDESCRIPTION VARCHAR2 (50) Not Null
FOODSUBCATDESCRIPTION VARCHAR2 (50) Not Null
UNITOFMEASURECD VARCHAR2 (6) Not Null
COMMENT_TEST VARCHAR2 (30) Not Null
CREATEUSERID VARCHAR2 (20)
CREATEDTTM DATE
MODIFYUSERID VARCHAR2 (20)
MODIFYDTTM DATE
SUBCATSHORTDESCRIPTION VARCHAR2 (50)
ACTIVE VARCHAR2 (1)

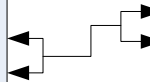

## Food Prescription Clean up view

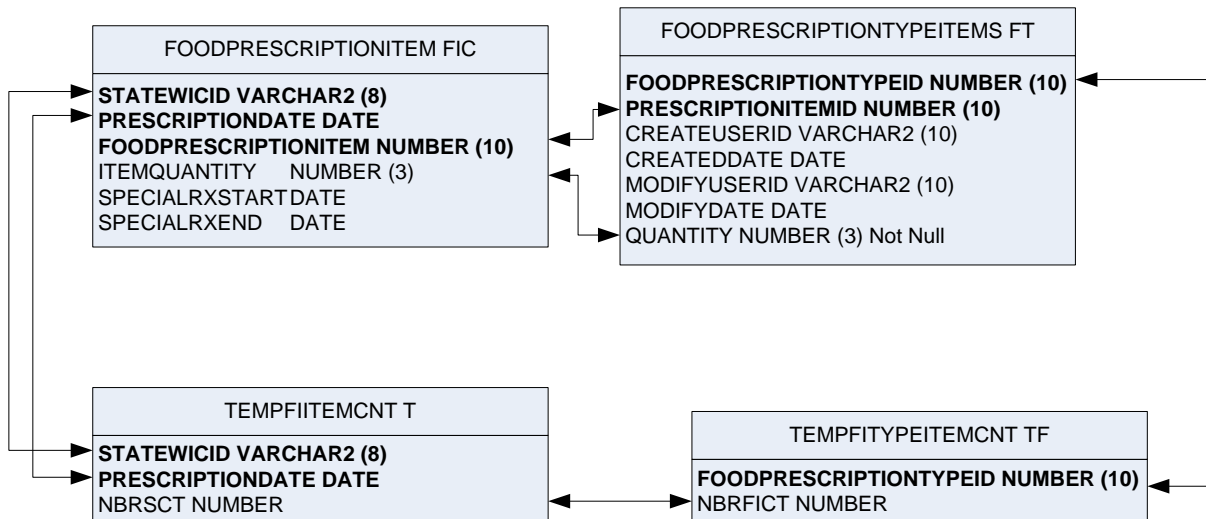

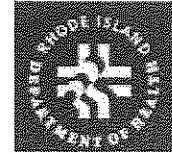

**SYSTEM MODIFICATION REQUEST**  
Rhode Island WEBS System Project

Title: RI10-12 KidsNet Communication

Date: July 19, 2011

Prepared By: Lee Postier

Requested By: Donna Bruce

Date of Request: January 19, 2010

Date Needed: November 30, 2011



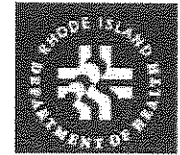

**SYSTEM MODIFICATION REQUEST  
Rhode Island WEBS System Project**

**SPECS FOR KIDSNET/WIC PROJECT**

**Detailed description of request: (Attach additional sheets as needed. If a new report, attach a mockup of the proposed report layout. If a bug fix, include DFDD citation.)**

Currently, WIC users are required to load, login and query two separate applications if they need to view KIDSNET Lead or Immunizations data in addition to WIC data from their system. This project will connect the two systems so that, once a child is located in the WIC application, Lead and Immunization data will be available without the need to login to the KIDSNET web application.

The purpose of this project is to allow WIC users (staff at the Women, Infants and Children sites in Rhode Island) to have easy access to KIDSNET Lead and Immunization data without the need to log into KIDSNET and to load any missing lead data from KIDSNET into WIC.

This project will be a collaborative effort between the RI Department of Health, the technical support staff for HEALTH and the WIC system administrators (CSC). RI HEALTH will coordinate changes with CSC.

In addition, the WIC files (wic\_visit and wic\_participant) will be uploaded automatically, thereby eliminating the need to do so manually. The automation of this process will allow the files to be uploaded weekly instead of monthly, as is currently the case

Children will be matched between WIC and KIDSNET by using the WIC Participant ID number and Date of Birth.

***Lead Blood Test Data***

KIDSNET will ftp a semi-colon delimited flat file to a predetermined sftp server from which CSC WIC will download (pull) the file containing the KIDSNET lead blood test data.

To accomplish this, the RI Department of Health will automatically upload (push) the LEAD files on a weekly basis to a secure CSC SFTP site.

CSC will notify Evan Bessette (KIDSNET WIC Data Manager) at the Rhode Island Department of Health if the weekly Lead data upload is not received.



**SYSTEM MODIFICATION REQUEST**  
Rhode Island WEBS System Project

The file will contain the following fields

Data Element
<b>CHILD INFORMATION</b>
FileName
childFirstName
childLastName
childWicId
childDateOfBirth
leadTestDate
pbbResult
PhysicianFirstName
PhysicianLastName

Removed riHealthapplicationId

Added PhysicianFirstName and PhysicianLastName

Physician name will be stored, but not displayed

Changed ResponseDateTime to FileCreationDate

Proposed naming convention for the file - KDWPYYYYMMDD

Storyboard Requirements:	Responsible Party
1. If an exact KIDSNET match was found for that child and there is lead data in KIDSNET that is not in WIC, store the new lead data in the WIC table with an indicator that the data came from KIDSNET.	CSC
2. If the data came from KIDSNET, display text "KIDSNET" next to the test data on the HT/WT/Blood tab	CSC
3. All lead data will be viewable through the HT/WT/Blood tab (in the "Blood" subsection) of the WIC application. (The user will NOT be taken to the KIDSNET LEAD screen.)	CSC
4. The following changes should also be included: a. Remove "E.P. (ug/dll)" field will be replaced by KidsNet indicator on the Add Blood Measurement window. b. If the most recent Lead test (whether WIC or KIDSNET)	CSC

- |  |  |
|--|--|
| <p>shows that the child is lead poisoned (if the lead PpB result is &gt; 10), then ensure that the Lead Risk Factor flag in the WIC system is set to True.</p> <p>c. Add Blood Lead Date field and Physician Name? field to the "Add Blood Measurement" screen. Physician name will be stored, but not displayed</p> |  |
|--|--|

### ***Initial Load of KIDSNET Historical Lead Data***

On a one time basis, the CSC WIC system will accept either on file or a series of files in the format described above which will contain the historic KIDSNET lead test information. This information will be preloaded into the CSC WIC system. Whether historical or current lead test data is being processed by the CSC WIC system, the WIC system will determine if the data is new or if it is updated information. CSC will add new or updated information to the CSC WIC system.

### ***WIC-KIDSNET Automatic Participant File Upload***

Currently, the WIC Visit and WIC Participant extract files must be manually uploaded to the Rhode Island Web File Repository (WFR) every month. Instead, this process must be automated and, therefore, will occur weekly rather than monthly.

To accomplish this, the RI Department of Health would prefer to automatically download (pull) the WIC files from a secure CSC SFTP. For this to work, RI will need the proper URL and credentials to perform the download on a weekly basis.

KIDSNET can provide an example of a semicolon delimited file containing de-identified data upon request. However, exactly the same extract file format as is currently sent should be used with no modification.



Wp2kn.dat



Wv2kn.dat

Proposed naming convention for the file – wp2knYYYYMMDD and wv2knYYYYMMD

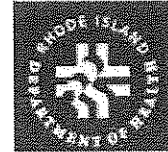

***WIC Immunization Tab Display***

When the CSC WIC application immunization tab is clicked, the CSC WIC application will display the KIDSNET web application printer friendly immunization page obtained from the KIDSNET web application URL (e.g. Test vs. Production).

In order to accomplish this, the CSC WIC application will dynamically create the KIDSNET immunization page web address (URL) as described below in the Authentication section.

<b>Storyboard Requirements:</b>	<b>Responsible Party</b>
<p>1. While the WIC system does have a space for immunizations, this section is not currently used and will not be populated in the same way as the proposed Lead process. Instead, when the child is selected in the WIC application, a link to the KIDSNET immunization page will be generated and included in the Web service response from KIDSNET. Authentication information will be encrypted and embedded in the link along with child identification information. The immunization page from KIDSNET contains a list of administered vaccines and recommendations regarding when vaccines should be administered next for the child. The page will also indicate whether the vaccine administered to-date was correctly administered according to the ACIP tables.</p> <p>a. There will be no navigation to other areas of KIDSNET included on the page.</p>	<p>KIDSNET</p> <p>CSC</p>
<p>2. If there is a matching child in KIDSNET, but the child does not have any immunization data, display a blank KIDSNET immunizations page (so that the user can see the immunization recommendations for that child)</p>	<p>CSC</p>



**Authentication**

The following information will be included in the URL string when the CSC WIC application requests the KIDSNET web application immunization page.

<b>wicUser</b>	User Id of WIC system user
<b>wid</b>	WIC participant Id
<b>dob</b>	Child date of birth (CCYYMMDD)
<b>app</b>	"wicApp".
<b>ts</b>	Use GMT
<b>dwp</b>	The hashed userToken will use an agreed upon secret key (to be discussed later) to encrypt the following information via the SHA1 Message Digest Algorithm: 1) WIC User Id 2) WIC Participant Id 3) Date of birth (CCYYMMDD) 4) Application Id

Example of URL:

<https://kidsnet.health.ri.gov/kidsnet-play/wic.req?wicUser=sjones&wid=123456&dob=ccyymmdd&app=wicApp&ts=1315325219933&dwp=gms3FDyoyXL2Z60GpZi0M303c6kD>

HLN Consulting, LLC, can assist CSC regarding how to create the hashed userToken mentioned above.

SYSTEM MODIFICATION REQUEST  
Rhode Island WEBS System Project

Draft Example of KIDSNET Immunization displayed in the WIC application:

Demographics | HIV/STI/STD | VENA | Risk Factors | Food Prescription | Nutrition Education  
 Checks History | Immunizations | Referrals | Health Information | Income History | Appointments

**Form**

### Immunization

Child Information - 09/16/2011

Name: [REDACTED] KIDSNET ID: [REDACTED]  
 Date Of Birth: [REDACTED] Age: [REDACTED] Gender: FEMALE  
 KIDSNET Status: [REDACTED] PCP: DOH TEST PRACTICE  
 Parent/Guardian: [REDACTED] Date of birth: 02/11/1980

View Vaccine Recommendations (Scroll Right)

Valid Doses	1	2	3	4	5	NEXT DUE
<b>Hepatitis B</b> 3 valid doses	11/04/2004 HEPB CHILD 1m 3d	02/11/2005 Pediarix 3m 10d	04/11/2005 Pediarix 5m 10d [3]	06/15/2005 Pediarix 7m 14d		End of Series Reached

Consent

2:03 PM 8/16/2011

Demographics | HIV/STI/STD | VENA | Risk Factors | Food Prescription | Nutrition Education  
 Checks History | Immunizations | Referrals | Health Information | Income History | Appointments

**Form**

Valid Doses	1	2	3	4	5	NEXT DUE
<b>Hepatitis B</b> 3 valid doses	11/04/2004 HEPB CHILD 1m 3d	02/11/2005 Pediarix 3m 10d	04/11/2005 Pediarix 5m 10d [3]	06/15/2005 Pediarix 7m 14d		End of Series Reached
<b>DTaP</b> 4 valid doses	02/11/2005 Pediarix 3m 10d	04/11/2005 Pediarix 5m 10d	06/15/2005 Pediarix 7m 14d	08/08/2006 DTaP 19m 5d		<b>Due Now</b> (11/01/2008 - 11/01/2011) Dose 5
<b>PCV</b> 4 valid doses	02/11/2005 Prevnar 7 3m 10d	04/11/2005 Prevnar 7 5m 10d	06/15/2005 Prevnar 7 7m 14d	12/06/2005 Prevnar 7 12m 5d		End of Series Reached
<b>Polio</b> 3 valid doses	02/11/2005 Pediarix 3m 10d	04/11/2005 Pediarix 5m 10d	06/15/2005 Pediarix 7m 14d			<b>Due Now</b> (11/01/2008 - 11/01/2011) Dose 4
<b>Hib</b>	02/11/2005 Pediarix 3m 10d	04/11/2005 Pediarix 5m 10d	06/15/2005 Pediarix 7m 14d			End of Series

Consent

2:03 PM 8/16/2011

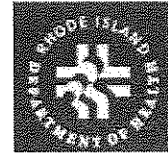

**SYSTEM MODIFICATION REQUEST**  
**Rhode Island WEBS System Project**

**System Impact Overview (Risk Analysis)**

The risk assessment of this work request is 1 based a scale of 1-5 (1=low risk). The modifications will require unit and quality assurance testing to minimize the impact.

**Resolved Issues**

<i>Date</i>	<i>Person</i>	<i>Description of Issue &amp; Resolution</i>

**Outstanding Issues**

<i>Date</i>	<i>Person</i>	<i>Description of Issue</i>

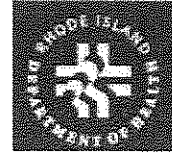

**SYSTEM MODIFICATION REQUEST**  
Rhode Island WEBS System Project

**Project Estimate**

The following cost breakdown is provided for informational purposes only and CSC Covansys will provide the services described in this SMR on a fixed price basis.

Activity	Hours	Rate	Cost
<b>Costs Incurred - Work Completed To Date:</b>			
JAD Session Time	0	\$ 99.00	\$ -
Travel Expenses Incurred (list in order by trip)	0	\$ 99.00	\$ -
Develop System Design Section	0	\$ 99.00	\$ -
Develop Conceptual Design Document (if required)	0	\$ 99.00	\$ -
Prepare System Design Document	4	\$ 99.00	\$ 396.00
<b>Total:</b>	<b>4</b>		<b>\$ 396.00</b>
 <b>Work to be Completed – FIXED Price:</b>			
Project Management	10	\$ 99.00	\$ 990.00
Software Modifications & Unit Testing	140	\$ 99.00	\$ 13,860.00
Help Text Modifications	24	\$ 99.00	\$ 2,376.00
Release Notes Preparation	0	\$ 99.00	\$ -
System Documentation Modifications	0	\$ 99.00	\$ -
Computer-based Training (CBT) Modifications	0	\$ 99.00	\$ -
Quality Assurance Testing	45	\$ 99.00	\$ 4,455.00
UAT Support	0	\$ 99.00	\$ -
IT Activities	30.75	\$ 99.00	\$ 3,044.25
Database Activities	0	\$ 99.00	\$ -
Training Coordinator	0	\$ 99.00	\$ -
<b>Total:</b>	<b>249.75</b>		<b>\$ 24,725.25</b>
<b>Grand Total:</b>	<b>253.75</b>		<b>\$ 25,121.25</b>

One time cost for SFTP software of \$650.00 is included in the IT Activities.

**Rhode Island State Department of Health**

Name of Approver	Title/Department	Signature	Date

**CSC Corporation**

Name of Approver	Title/Department	Signature	Date



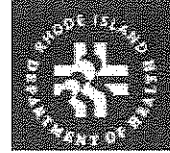

**SYSTEM MODIFICATION REQUEST**  
**Rhode Island WEBS System Project**

**Data Conversion**

**Security**

There are no issues or concerns with this work request regarding security.

**Infrastructure and Hardware**

There are no issues or concerns with this work request regarding the current infrastructure or the user hardware.

**User Acceptance Testing (UAT)**

There are no issues or concerns with this work request regarding UAT.

**Production Rollout (Implementation)**

Currently there are no issues or concerns regarding the Production Rollout process for this work request.

**Attachments**

There are no attachments that accompany this document.